



INVITATION TO TENDER

IMPORTANT NOTICES TO BIDDERS

Note to Bidders, there will be no public Opening for the purposes of this solicitation. See SI07 for further instructions.

REFERENCE TO PWGSC

All references to the Department of Public Works & Government Services Canada (PWGSC) in the instructions, general terms, conditions and clauses identified in the Invitation to Tender (ITT) by number, date and title, set out in the Standard Acquisition Clauses and Conditions Manual (<https://buyandsell.gc.ca/policy-and-guidelines/standard-acquisition-clauses-and-conditions-manual>) are to be replaced with the Correctional Service of Canada (CSC).

THIS DOCUMENT DOES NOT CONTAIN AN INDUSTRIAL SECURITY REQUIREMENT

LISTING OF SUBCONTRACTORS

As per GI06 of R2410T you should provide Appendix 3 at Bid closing a list of Subcontractors that have 20% or more of the tendered price value.

A9043T (2013-04-25) Reissue of Bid Solicitation

This bid solicitation cancels and supersedes previous bid solicitation number **21407-23-4326685** dated January 30, 2023 with a closing of February 17, 2023 at 10:00 a.m. EST. A debriefing or feedback session will be provided upon request to bidders/offerors/suppliers who bid on the previous solicitation.



TABLE OF CONTENTS

SPECIAL INSTRUCTIONS TO BIDDERS (SI)

- SI01 Bid Documents
- SI02 Enquiries During the Solicitation Period
- SI03 Optional Site Visit
- SI04 Revision of Bid
- SI05 Bid Security Requirements
- SI06 Submission of Bid
- SI07 Bid Results
- SI08 Insufficient Funding
- SI09 Bid Validity Period
- SI10 Rights of Canada
- SI11 Listing of Subcontractors and Suppliers
- SI12 Bid Challenge and Recourse Mechanisms
- SI13 Construction Documents
- SI14 Web Sites

R2710T GENERAL INSTRUCTIONS (GI) -CONSTRUCTION SERVICES – BID SECURITY REQUIREMENTS - (2022-12-01)

CONTRACT DOCUMENTS (CD)

SUPPLEMENTARY CONDITIONS (SC)

- SC01 Institutional Access Requirements
- SC02 Insurance Terms
- SC03 Supplemental General Conditions 4013 – Compliance with On-Site Measures, Standing Orders, Policies, and Rules
- SC04 SACC Manual Clause A3015C – Certifications – Contract
- SC05 Types and Amounts of Contract Security
- SC06 Compliance with applicable laws
- SC07 Workers Compensation
- SC08 Tuberculosis Testing
- SC09 Information Guide for Contractors
- SC10 Closure of Government Offices
- SC11 Contractor's Performance Evaluation Report

BID AND ACCEPTANCE FORM (BA)

- BA01 Identification
- BA02 Legal Name and Address of Bidder
- BA03 The Offer
- BA04 Bid Validity Period.
- BA05 Acceptance and Contract
- BA06 Construction Time
- BA07 Bid Security
- BA08 Signature

APPENDIX 1 - COMBINED PRICE FORM

APPENDIX 2 – INTEGRITY PROVISIONS

APPENDIX 3 – LISTING OF SUBCONTRACTORS AND SUPPLIERS

APPENDIX 4 – VOLUNTARY CERTIFICATION TO SUPPORT THE USE OF APPRENTICES

APPENDIX 5 – DEPARTMENTAL REPRESENTATIVES

ANNEX A – CERTIFICATE OF INSURANCE

ANNEX B – VOLUNTARY REPORT FOR APPRENTICES EMPLOYED DURING THE CONTRACT

ANNEX C – SCOPE OF WORK

ANNEX D – SPECIFICATIONS

ANNEX E – DRAWINGS

ANNEX F - CONTRACT SECURITY PROGRAM – APPLICATION FOR REGISTRATION



SPECIAL INSTRUCTIONS TO BIDDERS (SI)

SI01 BID DOCUMENTS

1. The following are the bid documents:
 - a. Invitation to Tender - Page 1;
 - b. Special Instructions to Bidders;
 - c. General Instructions – Construction Services – Bid Security Requirements, R2710T (2022-12-01)
 - d. Clauses & Conditions identified in “Contract Documents”;
 - e. Drawings and Specifications;
 - f. Bid and Acceptance Form and related Appendix(s); and
 - g. Any amendment issued prior to solicitation closing.

Submission of a bid constitutes acknowledgement that the Bidder has read and agrees to be bound by these documents.

2. General Instructions – Construction Services – Bid Security Requirements R2710T is incorporated by reference and is set out in the Standard Acquisition Clauses and Conditions (SACC) Manual, issued by Public Works and Government Services Canada (PWGSC). The SACC Manual is available on the PWGSC Web site:
<https://buyandsell.gc.ca/policy-and-guidelines/standard-acquisition-clauses-and-conditions-manual/5/R>

SI02 ENQUIRIES DURING THE SOLICITATION PERIOD

1. Enquiries regarding this bid must be submitted in writing to the Contracting Authority at the email address on the Invitation to Tender - Page 1 as early as possible within the solicitation period. Except for the approval of alternative materials as described in GI15 of R2710T, enquiries should be received no later than five (5) business days prior to the date set for solicitation closing to allow sufficient time to provide a response. Enquiries received after that time may not result in an answer being provided.
2. To ensure consistency and quality of the information provided to Bidders, the Contracting Authority will examine the content of the enquiry and will decide whether or not to issue an amendment.
3. All enquiries and other communications related to this bid sent throughout the solicitation period must be directed ONLY to the Contracting Authority named on the Invitation to Tender - Page 1. Failure to comply with this requirement may result in the bid being declared non-responsive.

SI03 OPTIONAL SITE VISIT

A9038T (2022-06-20) – Optional site visit

It is recommended that the Bidder or a representative of the Bidder visit the work site.

Arrangements have been made for the site visit to be held at **Collins Bay Institution, 1455 Bath Road, Kingston Ontario, K7L 4V7 on March 17, 2023**. The site visit will begin at **10:00 a.m. EST**, at the Front Entrance.

Bidders are requested to communicate with the Contracting Authority no later than **Wednesday March 15, 2023 at 10:00 p.m. EST** to confirm attendance and provide the name(s) of the person(s) who will attend. Bidders may be requested to sign an attendance sheet. Bidders who do not attend or do not send a representative will not be given an alternative appointment but they will not be precluded from submitting a bid. Any clarifications or changes to the bid solicitation resulting from the site visit will be included as an amendment to the bid solicitation.

Safety attire: in order to be guaranteed access to the site visit all persons should have the proper personal protection equipment (including, but not limited to safety glasses, footwear, vests and hard hats). Bidder's personnel and individuals who do not have the proper safety attire may be denied access to the site.

SI04 REVISION OF BID

Section GI10 Revision of bid of General Instructions – Construction Services – Bid Security Requirements R2710T is amended as follows:



Delete: Section GI10 Revision of bid in its entirety.

Insert: GI10 Revision of bid:

1. Bidders may revise a bid submitted in accordance with these instructions by email provided the revision is received at the CSC bid submission email address, on or before the date and time set for the closing of the solicitation. The email must be sent from the Bidder's email address, bear a signature that identifies the Bidder, and include the following in the subject field.
 - a. Solicitation Number;
 - b. Name of Bidder; and
 - c. Invitation to Tender Closing Date and Time.
2. Bidders submitting a revision to a bid that includes unit prices must clearly identify the change(s) in the unit price(s) and the specific item(s) to which each change applies.
3. Bidders submitting an email to confirm an earlier revision must clearly identify this email as a confirmation.
4. Failure to comply with any of the above provisions will result in the rejection of the non-compliant revision(s) only. CSC will evaluate the bid based on the original bid submitted and all other compliant revision(s).

SI05 BID SECURITY REQUIREMENTS

R2710T - General Instructions - Construction Services - Bid Security Requirements is modified as follow:

Delete GI08.2 and replace with the following:

2. A bid bond (form PWGSC-TPSGC 504) must be in an approved form, properly completed, with valid and enforceable signatures and sealed by the approved bonding company whose bonds are acceptable to Canada either at the time of solicitation closing or as identified in Treasury Board Appendix L, Acceptable Bonding Companies.
 - 2.1 A bid bond may be submitted in an electronic format (Electronic Bonding (E-Bond)) if it meets the following criteria:
 - a. The version submitted by the Bidder must be an electronic encrypted file with embedded digital certificate verifiable by Canada with respect to the totality and wholeness of the bond form, including: the content; all digital signatures; all digital seals; with the Surety Company, or an approved verification service provider of the Surety Company.
 - b. The version submitted must be viewable, printable and storable in standard electronic file formats compatible with Canada, and in a single file, allowable format pdf.
 - c. The verification may be conducted by Canada immediately or at any time during the life of the Bond and at the discretion of Canada.
 - d. The results of the verification must provide a clear, immediate and printable indication of pass or fail regarding Item 2.1.a.
 - e. Submitting copies (**non-original, non-verifiable or scanned copy**) of signed and sealed bid bond are not acceptable. Failure to submit an original or verifiable bond will render the bid non-compliant. Non-compliant bids will be given no further consideration. A scanned copy of a bond does not constitute a digital bond.
 - 2.2 Bonds failing the verification process will NOT be considered valid.
 - 2.3 Bonds passing the verification process will be treated as original and authentic.

SI06 SUBMISSION OF BID

Section GI09 Submission of bid of General Instructions – Construction Services – Bid Security Requirements R2710T is amended as follows:

Delete: Section GI09 Submission of bid in its entirety.



Insert: GI09 Submission of bid:

1. Bidders must submit the Bid and Acceptance Form, duly completed, and the bid security only to Correctional Service of Canada (CSC) by the date, time and at the **CSC bid submission email address** indicated on Front Page of the Invitation to Tender. This email address is the only acceptable email address for Bidders to submit their Bid and Acceptance Form in response to this Invitation to Tender.
2. Bidders must submit their bid on or before the date and time set for solicitation closing.
3. Unless otherwise specified in the Special Instructions to Bidders
 - a. the bid must be in Canadian currency;
 - b. the requirement does not offer exchange rate fluctuation risk mitigation. CSC will not consider requests for exchange rate fluctuation risk mitigation. All bids including such provision will render the bid non-responsive.
4. Prior to submitting the bid, the Bidder should ensure that the following information is included in the subject field of their email:
 - a. Solicitation Number;
 - b. Name of Bidder; and
 - c. Invitation to Tender Closing Date and Time.
5. Timely and correct delivery of bids is the sole responsibility of the Bidder.
6. Canada will not be responsible for any failure attributable to the transmission or receipt of the bid by email including, but not limited to, the following:
 - i. Receipt of a garbled, corrupted or incomplete bid;
 - ii. Availability or condition of the email service;
 - iii. Incompatibility between the sending and receiving equipment;
 - iv. Delay in transmission or receipt of the bid;
 - v. Failure of the Bidder to properly identify the bid;
 - vi. Illegibility of the bid;
 - vii. Security of bid data;
 - viii. Failure of the Bidder to send the bid to the correct email address;
 - ix. Connectivity issues; or
 - x. Email attachments that are blocked or not received even though the Bidder's email has been successfully delivered.
7. CSC will send an acknowledgement of receipt of the Bidder's email by email from the email address provided for the submission of bids. This acknowledgement will confirm only the receipt of the Bidder's email and will not confirm if all of the Bidder's email attachments have been received, may be opened nor if their contents are readable. CSC will not respond to follow-up emails from Bidders requesting confirmation of attachments.
8. Bidders must ensure they are using the correct email address for bid submission and should not rely on the accuracy of copying and pasting the email address from the Invitation to Tender document cover page.
9. A bid transmitted by a Bidder to the CSC submission email address constitutes the Bidder's formal bid.
10. Bidders are to note that CSC's email system has a limit of 10 MB per single email message. CSC's email system will reject emails with the following attachments: batch files, executable files, and image files in the following formats: JPEG, GIF, TIFF. Canada will not accept encrypted emails or emails that include attachments with passwords.

SI07 BID RESULTS

1. The responsive bid carrying the lowest price will be recommended for contract award.



2. CSC will send an official letter by email to unsuccessful bidders to inform them of the name of the winning bidder as well as the total contract value.

SI08 INSUFFICIENT FUNDING

In the event that the lowest compliant bid exceeds the amount of funding allocated by Canada for the Work, Canada in its sole discretion may:

- a. cancel the solicitation; or
- b. obtain additional funding and award the Contract to the Bidder submitting the lowest compliant bid.

SI09 BID VALIDITY PERIOD

1. Canada reserves the right to seek an extension to the bid validity period prescribed in BA04 of the Bid and Acceptance Form. Upon notification in writing from Canada, Bidders will have the option to either accept or reject the proposed extension.
2. If the extension referred to in paragraph 1 above is accepted, in writing, by all those who submitted bids, then Canada will continue immediately with the evaluation of the bids and its approvals processes.
3. If the extension referred to in paragraph 1 above is not accepted in writing by all those who submitted bids then Canada will, at its sole discretion, either
 - a. continue to evaluate the bids of those who have accepted the proposed extension and seek the necessary approvals; or
 - b. cancel the invitation to tender.
4. The provisions expressed herein do not in any manner limit Canada's rights in law or under GI11 of R2710T.

SI10 RIGHTS OF CANADA

1. Canada reserves the right to:
 - a. Reject any or all bids received in response to the bid solicitation;
 - b. Enter into negotiations with bidders on any or all aspects of their bids;
 - c. Accept any bid in whole or in part without negotiations;
 - d. Cancel the bid solicitation at any time;
 - e. Reissue the bid solicitation;
 - f. If no compliant bids are received and the requirement is not substantially modified, reissue the bid solicitation by inviting only the bidders who bid to resubmit bids within a period designated by Canada; and
 - g. Negotiate with the sole compliant Bidder to ensure best value to Canada.

SI11 LISTING OF SUBCONTRACTORS AND SUPPLIERS

R2710T, GI07 has been amended to the following.

GI07 (2015-02-25) Listing of Subcontractors and Suppliers

The Bidder must submit the names of Subcontractors and Suppliers for the part or parts of the Work listed. See APPENDIX 3 **Failure to do so will result in the disqualification of its bid.**

SI12 BID CHALLENGE AND RECOURSE MECHANISMS

Canada encourages suppliers to first bring their concerns to the attention of the Contracting Authority.

The Office of the Procurement Ombudsman (OPO) was established by the Government of Canada to provide an impartial, independent venue for Canadian bidders to raise complaints regarding the award of certain federal contracts



under \$26,400 for goods and \$105,700 for services. If you have concerns regarding the award of a federal contract below these dollar amounts, you may contact OPO by e-mail at [the Office of the Procurement Ombudsman email address](#), by telephone at 1-866-734-5169, or by web at [the Office of the Procurement Ombudsman website](#). For more information on OPO's services or to determine if your concerns are within the Ombudsman's mandate, please see the [Procurement Ombudsman Regulations](#) or visit the [OPO website](#).

SI13 CONSTRUCTION DOCUMENTS

The successful Contractor will be provided with one electronic or paper copy of the sealed and signed drawings, the specifications and the amendments upon acceptance of the offer. Additional copies, up to a maximum of 2, will be provided free of charge upon request by the Contractor. Obtaining more copies will be the responsibility of the Contractor including costs.

CSC may furnish additional drawings for clarification. These additional drawings will have the same meaning and intent as if they were included in the original plans referred to in the Contract Documents.

The Contractor must check the existing building dimensions before starting work and ordering any materials. The Contractor must report discrepancies affecting the work shown on the drawings to the CSC Project Manager for clarification and final decision. It is the responsibility of the Contractor to visit the site personally to verify or obtain dimensions. Any dimensions given are approximate and CSC assumes no responsibility for the accuracy of these dimensions.

SI14 WEB SITES

The connection to some of the Web sites in the solicitation documents is established by the use of hyperlinks. The following is a list of the addresses of the Web sites:

Buy and Sell

<https://buyandsell.gc.ca/>

Canadian economic sanctions

<http://www.international.gc.ca/sanctions/index.aspx?lang=eng>

Contractor Performance Evaluation Report (Form PWGSC-TPSGC 2913)

<http://www.tpsgc-pwgsc.gc.ca/app-acq/forms/documents/2913.pdf>

Bid Bond (form PWGSC-TPSGC 504)

<http://www.tpsgc-pwgsc.gc.ca/app-acq/forms/documents/504.pdf>

Performance Bond (form PWGSC-TPSGC 505)

http://www.tpsgc-pwgsc.gc.ca/app-acq/forms/documents/505_eng.pdf

Labour and Material Payment Bond (form PWGWSC-TPSGC 506)

<http://www.tpsgc-pwgsc.gc.ca/app-acq/forms/documents/506.pdf>

Standard Acquisition Clauses and Conditions (SACC) Manual

<https://buyandsell.gc.ca/policy-and-guidelines/standard-acquisition-clauses-and-conditions-manual/5/R>

PWGSC, Contract Security Program

<http://ssi-iss.tpsgc-pwgsc.gc.ca/index-eng.html>

PWGSC, Code of Conduct and Certifications

<https://www.tpsgc-pwgsc.gc.ca/app-acq/cndt-cndct/cca-ccp-eng.html>

Construction and Consultant Services Contract Administration Forms Real Property Contracting

<http://www.tpsgc-pwgsc.gc.ca/app-acq/forms/formulaires-forms-eng.html>

Declaration Form

<http://www.tpsgc-pwgsc.gc.ca/ci-if/formulaire-form-eng.html>



Trade agreements

<https://buyandsell.gc.ca/policy-and-guidelines/Policy-and-Legal-Framework/Trade-Agreements>

Correctional service of Canada website: <http://www.csc-scc.gc.ca/index-eng.shtml>

R2710T GENERAL INSTRUCTIONS-CONSTRUCTION SERVICES – BID SECURITY REQUIREMENTS (GI) - (2022-12-01)

The following GI's are included by reference and are available at the following Web Site <https://buyandsell.gc.ca/policy-and-guidelines/standard-acquisition-clauses-and-conditions-manual/5/R>

- GI01 Integrity Provisions - Bid
- GI02 Completion of Bid
- GI03 Identity or Legal Capacity of the Bidder
- GI04 Applicable taxes
- GI05 Capital Development and Redevelopment Charges
- GI06 Registry and Pre-qualification of Floating Plant
- GI07 Listing of Subcontractors and Suppliers
- GI08 Bid Security Requirements
- GI09 Submission of Bid
- GI10 Revision of Bid
- GI11 Rejection of Bid
- GI12 Bid Costs
- GI13 Procurement Business Number
- GI14 Compliance with Applicable Laws
- GI15 Approval of Alternative Materials
- GI16 Performance Evaluation
- GI17 Conflict of Interest-Unfair Advantage
- GI18 Code of Conduct for Procurement-bid

CONTRACT DOCUMENTS (CD)

1. The following are the contract documents:

- a. Contract Page when signed by Canada;
- b. Duly completed Bid and Acceptance Form and any Appendices attached thereto;
- c. Drawings and Specifications;
- d. General Conditions and clauses

GC1	General Provisions – Construction Services	R2810D	(2022-12-01);
GC2	Administration of the Contract	R2820D	(2016-01-28);
GC3	Execution and Control of the Work	R2830D	(2019-11-28);
GC4	Protective Measures	R2840D	(2008-05-12);
GC5	Terms of Payment	R2850D	(2019-11-28);
GC6	Delays and Changes in the Work – Construction Services	R2865D	(2019-05-30);
GC7	Default, Suspension or Termination of Contract	R2870D	(2018-06-21);
GC 8	Dispute Resolution	R2880D	(2019-11-28);
GC9	Contract Security	R2890D	(2022-12-01);
GC10	Insurance	R2900D	(2008-05-12);
	Allowable Costs for Contract Charges Under GC6.4.1	R2950D	(2015-02-25)
- e. Supplementary Conditions
- f. Any amendment issued or any allowable bid revision received before the date and time set for solicitation closing;
- g. Any amendment incorporated by mutual agreement between Canada and the Contractor before acceptance of the bid; and
- h. Any amendment or variation of the contract documents that is made in accordance with the General Conditions.

2. The documents identified by title, number and date above are incorporated by reference and are set out in the Standard Acquisition Clauses and Conditions (SACC) Manual, issued by Public Works and Government Services Canada (PWGSC). The SACC Manual is available on the PWGSC Web site:



<https://buyandsell.gc.ca/policy-and-guidelines/standard-acquisition-clauses-and-conditions-manual>

3. The language of the contract documents is the language of the Bid and Acceptance Form submitted.

SUPPLEMENTARY CONDITIONS (SC)

SC01 INSTITUTIONAL ACCESS REQUIREMENTS

1. NIL security screening required as there is no access to sensitive information or assets. Contractor personnel will be escorted at all times by Correctional Service Canada personnel or those authorized by CSC on its behalf. CSC has developed very stringent internal policies to ensure that the security of institutional operations is not compromised.
2. Contractor personnel must adhere to institutional requirements for the conduct of searches by Correctional Service Canada prior to admittance to the institution/site. Correctional Service Canada reserves the right to deny access to any institution/site or part thereof of any Contractor personnel, at any time

SC02 INSURANCE TERMS

1. Insurance Contracts
 - a. The Contractor must, at the Contractor's expense, obtain and maintain insurance contracts in accordance with the requirements of the Certificate of Insurance. Coverage must be placed with an Insurer licensed to carry out business in Canada.
 - b. Compliance with the insurance requirements does not release the Contractor from or reduce its liability under the Contract. The Contractor is responsible for deciding if additional insurance coverage is necessary to fulfill its obligation under the Contract and to ensure compliance with any applicable law. Any additional insurance coverage is at the Contractor's expense, and for its own benefit and protection.
2. Period of Insurance
 - a. The policies required in the Certificate of Insurance must be in force from the date of contract award and be maintained throughout the duration of the Contract.
 - b. The Contractor must be responsible to provide and maintain coverage for Products/Completed Operations hazards on its Commercial General Liability insurance policy, for a period of six (6) years beyond the date of the Certificate of Substantial Performance.
3. Proof of Insurance
 - a. Before commencement of the Work, and no later than thirty (30) days after contract award, the Contractor must deposit with Canada a Certificate of Insurance on the form attached herein.
 - b. Upon request by Canada, the Contractor must provide originals or certified true copies of all contracts of insurance maintained by the Contractor pursuant to the Certificate of Insurance.

4. Insurance Proceeds

In the event of a claim, the Contractor must, without delay, do such things and execute such documents as are necessary to effect payment of the proceeds.

5. Deductible

The payment of monies up to the deductible amount made in satisfaction of a claim must be borne by the Contractor.

SC03 SUPPLEMENTAL GENERAL CONDITIONS 4013 (2022-06-20) – COMPLIANCE WITH ON-SITE MEASURES, STANDING ORDERS, POLICIES, AND RULES – APPLY TO AND FORM PART OF THE CONTRACT

The Contractor must comply and ensure that its employees and subcontractors comply with all security measures, standing orders, policies or other rules in force at the site where the Work is performed.



SC04 SACC MANUAL CLAUSE A3015C (2014-06-26) – CERTIFICATIONS – CONTRACT

Compliance with the certifications provided by the Contractor in its bid is a condition of the Contract and subject to verification by Canada during the term of the Contract. If the Contractor does not comply with any certification or it is determined that any certification made by the Contractor in its bid is untrue, whether made knowingly or unknowingly, Canada has the right, pursuant to the default provision of the Contract, to terminate the Contract for default.

SC05 TYPES AND AMOUNTS OF CONTRACT SECURITY

Remove and Replace GC9.2.2. with the following

A performance bond (form PWGSC-TPSGC 505) and a labour and material payment bond (form PWGSC-TPSGC 506) referred to in subparagraph 1)(a) of GC9.2 shall be in a form and be issued by a bonding or surety company (see Treasury Board Appendix L, Acceptable Bonding Companies) that is approved by Canada. They can be in the form of Signed and Sealed paper version OR electronic digital version.

Electronic digital versions must meet the following;

1. A performance bond and a labour and material payment bond may be submitted in an electronic or digital format if it meets the following criteria:
 - 1.1. The versions submitted by the Contractor must be verifiable by Canada with respect to the totality and wholeness of the bonds form, including: the content; all digital signatures; all digital seals; with the Surety Company, or an approved verification service provider of the Surety Company.
 - 1.2. The versions submitted must be viewable, printable and storable in standard electronic file formats compatible with Canada's systems, and in a single file. Allowable formats include pdf.
 - 1.3. The verification may be conducted by Canada immediately or at any time during the life of the bonds and at the discretion of Canada with no requirement for passwords or fees.
 - 1.4. The results of the verification must provide a clear, immediate and printable indication of pass or fail regarding Item 1.1.
2. Bonds failing the verification process will NOT be considered to be valid.

SC06 COMPLIANCE WITH APPLICABLE LAWS:

The Contractor must comply with all laws, regulations rules instructions and directives applicable to the performance of the Work or any part thereof in force on the site where the Work is to be performed. The Contractor must also comply with all laws, regulations, rules, instructions and directives applicable to the agents and servants of the Crown. The Contractor must also require compliance therewith by all of its subcontractors. Evidence of compliance with such laws, regulations and rules must be furnished by the Contractor to the Contracting Authority at such times as the Contracting Authority may reasonably request.

Unless otherwise provided in the contract, the Contractor must obtain all permits and hold all certificates and licenses required for the performance of the Work.

Details on existing CSC policies can be found at www.csc-scc.gc.ca or any other CSC web page designated for such purpose.

SC07 WORKERS COMPENSATION

It is mandatory that every Contractor contracted for work must have an account with the applicable Provincial or Territorial Workers Compensation Board/Commission, and coverage shall be extended to cover all employees.

SC08 TUBERCULOSIS TESTING:



It is a condition of this contract that the Contractor or any employees of the Contractor who require entry into a Correctional Service of Canada Institution to fulfil the conditions of the contract may, at the sole discretion of the Warden, be required to provide proof of and results of a recent tuberculin test for the purpose of determining their TB infection status.

Failure to provide proof of and results of a tuberculin test may result in the termination of the contract.

All costs related to such testing will be at the sole expense of the Contractor.

SC09 INFORMATION GUIDE FOR CONTRACTORS

Prior to the commencement of any work, the Contractor certifies that its employees, or employees of its subcontractors, working under contract for CSC, will complete the applicable Module(s) and retain the signed checklist(s) from the CSC Information Guide for Contractors" website: www.bit.do/CSC-EN .

SC10 CLOSURE OF GOVERNMENT OFFICES

Contractor personnel are employees of the Contractor and are paid by the Contractor on the basis of services rendered. Where the Contractor or the Contractor's employees are providing services on government premises pursuant to this Contract and the said premises become non accessible due to evacuation or closure of government offices, and consequently no Work is being performed as a result of the closure, Canada will not be liable for payment to the Contractor for the period of closure.

Contractors working at CSC sites should be aware that they may be faced with delay or refusal of entry to certain areas at certain times even if prior arrangements for access may have been made. Contractors are advised to call in advance of travel to ensure that planned access is still available.

SC11 CONTRACTOR'S PERFORMANCE EVALUATION REPORT

CSC will evaluate the Contractor's performance during the execution of the work and when it is completed using PWGSC – TPSGC form 2913 "Contractor Performance Evaluation Report Form (CPERF)". This evaluation will be based on the quality of the execution of the work, timeliness, management of on-site health and safety and the general management of the Contractor's work in relation to the effort required by the Department's employees in the administration of the contract. A completed performance evaluation report will be sent to the Contractor when the work has been completed for all projects.



BID AND ACCEPTANCE FORM (BA)

BA01 IDENTIFICATION

Opioid Prevention Site (OPS) – Collins Bay Institution

BA02 BUSINESS NAME AND ADDRESS OF BIDDER

Legal Name:				
Operating Name (if any):				
Address:				
Telephone:		Fax:		PBN:
E-mail address:				
Contract Security Program Organisation Number (when required)				

BA03 THE OFFER

The Bidder offers to Canada to perform and complete the Work for the above named project in accordance with the Bid Documents for the Total Bid Amount of

\$ _____ excluding applicable tax(es).
(amount in numbers)

BA04 BID VALIDITY PERIOD

The bid must not be withdrawn for a period of 90 days following the date of solicitation closing.

BA05 ACCEPTANCE AND CONTRACT

Upon acceptance of the Bidder's offer by Canada, a binding Contract will be formed between Canada and the Bidder. The documents forming the Contract will be the Contract Documents identified in "Contract Documents (CD)".

BA06 CONSTRUCTION TIME

The Contractor must perform and complete the work within 6 weeks from the date of notification of acceptance of the offer.

BA07 BID SECURITY

The Bidder must include bid security with its bid in accordance with GI0 8 - Bid Security Requirements of R2710T - General Instructions Construction Services – Bid Security Requirements.

BA08 SIGNATURE

Name and title of person authorized to sign on behalf of Bidder (Type or print)

Signature

Date



APPENDIX 1 - COMBINED PRICE FORM (1 page)

- 1) The prices per unit will govern in establishing the Total Extended Amount. Any arithmetical errors in this Appendix will be corrected by Canada.
- 2) Canada may reject the bid if any of the prices submitted do not reasonably reflect the cost of performing the part of the work to which that price applies.

LUMP SUM

The Lump Sum Amount designates Work to which a Lump Sum Arrangement applies.

- (a) Work included in the Lump Sum Amount represents all work not included in the unit price table.

LUMP SUM AMOUNT (LSA) Excluding applicable tax(es)
--



APPENDIX 2 – INTEGRITY PROVISIONS

List of names: all bidders, regardless of their status under the Policy, must submit the following information when participating in a procurement process or real property transaction:

- Bidders that are corporate entities, including those bidding as joint ventures, must provide a complete list of the names of all current directors or, for a privately owned corporation, the names of the owners of the corporation;
- Bidders bidding as sole proprietors, including sole proprietors bidding as joint ventures, must provide a complete list of the names of all owners; or
- Bidders that are a partnership do not need to provide a list of names.

If the list of names has not been received in a procurement process or real property transaction by the time the evaluation of bids or offers is completed, or has not been received in a procurement process or real property transaction where no bid/offer will be submitted, the Contracting Authority will inform the Bidder of a time within which to provide the information. Providing the required names is a mandatory requirement for award of a contract or real property agreement. Failure to provide the list of names within the time specified will render a bid or offer non-responsive, or the Bidder otherwise disqualified for award of a contract or real property agreement.



APPENDIX 3 - LISTING OF SUBCONTRACTORS AND SUPPLIERS

- 1) In accordance with GI07 – Listing of Subcontractors and Suppliers of R2710T – General Instructions – Construction Services – Bid Security Requirements the Bidder should provide a list of Subcontractors with his Bid.
- 2) The Bidder should submit the list of Subcontractors and for any portion of the Work valued at 20% or greater of the submitted In Price.

	Subcontractor	Division	Estimated value of work
1.			
2.			
3.			
4.			
5.			
6.			
7.			
8.			
9.			
10.			
11.			
12.			
13.			
14.			
15.			



APPENDIX 4 - VOLUNTARY CERTIFICATION TO SUPPORT THE USE OF APPRENTICES

(page 1 of 2)

PUBLIC WORKS AND GOVERNMENT SERVICES CANADA APPRENTICE PROCUREMENT INITIATIVE

1. To encourage employers to participate in apprenticeship training, Bidders, bidding on construction and maintenance contracts by Public Works and Government Services Canada (PWGSC) are being asked to sign a voluntary certification, signaling their commitment to hire and train apprentices.
2. Canada is facing skills shortages across various sectors and regions, especially in the skilled trades. Equipping Canadians with skills and training is a shared responsibility. The Government of Canada made a commitment to support the use of apprentices in federal construction and maintenance contracts. Contractors have an important role in supporting apprentices through hiring and training and are encouraged to certify that they are providing opportunities to apprentices as part of doing business with the Government of Canada.
3. The Government of Canada is encouraging apprenticeships and careers in the skilled trades. In addition, the government offers a tax credit to employers to encourage them to hire apprentices. Information on this tax measure administered by the Canada Revenue Agency can be found at: www.cra-arc.gc.ca. Employers are also encouraged to find out what additional information and supports are available from their respective provincial or territorial jurisdiction.
4. Signed certifications on page 2 of 2 will be used to better understand contractor use of apprentices on Government of Canada maintenance and construction contracts and may inform future policy and program development.
5. The Contractor hereby certifies the following:

In order to help meet demand for skilled trades people, the Contractor agrees to use, and require its subcontractors to use, reasonable commercial efforts to hire and train registered apprentices, to strive to fully utilize allowable apprenticeship ratios * and to respect any hiring requirements prescribed by provincial or territorial statutes

The Contractor hereby consents to this information being collected and held by PWGSC, and Employment and Social Development Canada to support work to gather data on the hiring and training of apprentices in federal construction and maintenance contracts.

To support this initiative, a voluntary certification signaling the Contractor's commitment to hire and train apprentices is available at page 2 of 2.

If you accept fill out and sign page 2 of 2.

** The journey-person-apprentice ratio is defined as the number of qualified/certified journeypersons that an employer must employ in a designated trade or occupation in order to be eligible to register an apprentice as determined by provincial/territorial (P/T) legislation, regulation, policy directive or by law issued by the responsible authority or agency.*



VOLUNTARY CERTIFICATION

(To be filled out and returned with bid on a voluntary basis)
(page 2 of 2)

Note: The contractor will be asked to fill out a report every six months or at project completion as per sample "Voluntary Reports for Apprentices Employed during the Contract" provided at Annex B.

Name:	
Signature:	
Company Name:	
Company Legal Name:	
Solicitation Number:	
Number of company employees:	
Number of apprentices planned to be working on this contract:	

Trades of those apprentices:



APPENDIX 5 - DEPARTMENTAL REPRESENTATIVES

TO BE PROVIDED AT CONTRACT AWARD.

Contracting Authority is:

Name: Elizabeth Lake

Title: Procurement Officer

Department: Contracting & Materiel Services

Division: Correctional Services of Canada

Telephone: 613 - 328 - 9647

E-mail: Elizabeth.lake@csc-scc.gc.ca

Technical Authority is:

Name: _____

Title: _____

Department: _____

Division: _____

Telephone: _____ - _____ - _____

E-mail: _____



ANNEX A – CERTIFICATE OF INSURANCE (not required at solicitation closing)

CERTIFICATE OF INSURANCE Page 1 of 2

Description and Location of Work OPS – Interim Requirements Collins Bay Institution	Contract No. 21407-23-4326685
	Project No.

Name of Insurer, Broker or Agent	Address (No., Street)	City	Province	Postal Code
----------------------------------	-----------------------	------	----------	-------------

Name of Insured (Contractor)	Address (No., Street)	City	Province	Postal Code
------------------------------	-----------------------	------	----------	-------------

Additional Insured
His Majesty the King in Right of Canada as represented by the Minister of Public Safety

Type of Insurance	Insurer Name and Policy Number	Inception Date D / M / Y	Expiry Date D / M / Y	Limits of Liability		
				Per Occurrence	Annual General Aggregate	Completed Operations Aggregate
Commercial General Liability				\$	\$	\$
Umbrella/Excess Liability				\$	\$	\$
Builder's Risk / Installation Floater				\$		
Pollution Liability				\$ <input type="checkbox"/> Per Incident <input type="checkbox"/> Per Occurrence		Aggregate \$
Insert other type of insurance as required				\$		

I certify that the above policies were issued by insurers in the course of their Insurance business in Canada, are currently in force and include the applicable insurance coverage's stated on page 2 of this Certificate of Insurance, including advance notice of cancellation / reduction in coverage.

Name of person authorized to sign on behalf of Insurer(s) (Officer, Agent, Broker)

Telephone number

Signature

Date D / M / Y



CERTIFICATE OF INSURANCE (not required at solicitation closing)

PAGE 2 of 2

General

The insurance policies required on page 1 of the Certificate of Insurance must be in force and must include the insurance coverage listed under the corresponding type of insurance on this page.

The policies must insure the Contractor and must include His Majesty the King in Right of Canada as represented by the Minister of Public Safety Canada as an additional Insured.

The Policy must be endorsed to provide the owner with not less than thirty (30) days notice in writing in advance of any cancellation, cancellation or change or amendment restricting coverage.

Without increasing the limit of liability, the policies must protect all insured parties to the full extent of coverage provided. Further, the policies must apply to each Insured in the same manner and to the same extent as if a separate policy had been issued to each.

Commercial General Liability.

The insurance coverage provided must not be substantially less than that provided by the latest edition of IBC form 2100.

The policy must either include or be endorsed to include coverage for the following exposures or hazards if the Work is subject thereto:

- a) Blasting;
- b) Pile driving and caisson work;
- c) Underpinning;
- d) Removal or weakening of support of any structure or land whether such support be natural or otherwise if the work is performed by the insured contractor.

The policy must have the following minimum limits:

- a) \$5,000,000 Each Occurrence Limit;
- b) \$10,000,000 General Aggregate Limit per policy year if the policy contains a General Aggregate; and
- c) \$5,000,000 Products/Completed Operations Aggregate Limit.

Umbrella or excess liability insurance may be used to achieve the required limits.

Builder's Risk / Installation Floater.

The insurance coverage provided must not be less than that provided by the latest edition of IBC forms 4042 and 4047.

The policy must permit use and occupancy of any of the projects, or any part thereof, where such use and occupancy is for the purposes for which a project is intended upon completion.

The policy may exclude or be endorsed to exclude coverage for loss or damage caused by asbestos, fungi or spores, cyber and terrorism.

The policy must have a limit that is **not less than the sum of the contract value** plus the declared value (if any) set forth in the contract documents of all material and equipment supplied by Canada at the site of the project to be incorporated into and form part of the finished work. If the value of the work is changed, the policy must be changed to reflect the revised contract value.

The policy must provide that the proceeds thereof are payable to Canada or as Canada may direct in accordance with GC10.2, "Insurance Proceeds" (<https://buyandsell.gc.ca/policy-and-guidelines/standards-acquisition-clauses-and-conditions-manual/5/R/R2900D/2>).

Contractors Pollution Liability

The policy must have a limit usual for a contract of this nature, but no less than \$1,000,000 per incident or occurrence and in the aggregate.



ANNEX C - SCOPE OF WORK

Project Name: OPS – Interim Requirements
Project Number: 440-2111-0
Institution: Collins Bay Institution
Contract Number: 1407-24-4326685

Objectives

The Correctional Service of Canada requires the services of a qualified general contractor to make modification to existing Medical Centre in building CBA14 within Collins Bay Institution located in Kingston ON.

Scope of Work

Nurses Station

- Supply and install new slab-to-slab partition walls with 38x140mm steel stud at 405mm On Centre (O.C) with 15.9mm abuse-resistant gypsum board on 15.9mm plywood both sides, affixed to concrete slab below and deck above. Secure top and bottom steel stud track to both slabs at 300mm O.C using expanding mechanical fastener. Allow for framing around existing services that are to remain at ceiling level. The layout must be in accordance with agreed drawing.
- Paint all new surfaces and items unless pre-finished. The project authority will determine the colours.
- Patch and Repair all affected existing finishes and surfaces, including paint, flooring, ceiling tiles and wall base.
- Modify existing acoustic ceiling tile grid to accommodate new walls as well mechanical and electrical equipment and systems. Provide new matching ceiling tiles and grid components as necessary. Revise lighting (including switches) as required; the new fixtures must match existing ones.
- Revise the fire suppression system in accordance with applicable codes.
- Supply and Install new one full height 2134mm h X 880 mm wide hollow metal door that matches the existing one, single side light – Georgian Wire, Lever handle to support BEST core. The institution will supply and install the BEST core.
- Supply and install new rubber cove base on both sides of new partition walls, Cove Base colour must match the existing colour.
- Supply and Install new electrical outlets X2 and LAN X2 in accordance with agreed drawing.
- Supply and install new emergency lighting in accordance with agreed drawing.

Injection Rooms: 114A/114B

- Remove and dispose of current drop ceil system in rooms 114A and 144B. Supply and install new suspended ceiling with 38 x140mm steel studs at 405 mm O.C with 15.9 mm abuse resistant gypsum board on $\frac{3}{4}$ -9F expanded metal mesh. Expanded metal mesh must be secured with welds or rivets. Ceiling height 2743.2 mm above finished floor (AFF).
- Ventilation – Remove and dispose of current ceiling mounted ventilation covers in rooms 114A/114B. Bring ductwork back to partition wall. Supply and install new wall mounted ligature resistant security ventilation covers (S or V-type grille) in all cells. The contractor must install grilles in accordance to CSC's Technical Criteria Document (TCD) (Section M-4).
- Lighting – Remove and dispose of current fluorescent lighting in rooms 114A/114B. Supply and install 1X new ceiling mounted LED vandal resistant light fixtures in each identified room.
- Replace existing fire sprinkler heads with flush-mount, tamper resistant sprinkler heads in each identified room.
- Supply and install one 10ga Stainless desk (762 mm x 1219 mm) secured to floor with tamper proof fasteners.
- Remove and dispose of existing wood office doors and frame in rooms 114A and 114B, supply and install new observation style detention doors and frames in accordance with CSC's TCD (see attached appendix)
- Walls – Paint all new surfaces and items unless pre-finished; Colours must match existing. Existing wall finishes to remain unless the project authority authorizes a change in finishes.
- Supply and install new rubber cove base in rooms 114A/114B, Cove Base colour must match existing.



Delivery and Security

- All of the contractor's employees entering the facility must report to the main entrance and pass through all security devices and screening before reporting to the identified work area.
- The contractor's employees must assemble at the main entrance. CSC will provide an escort, who will remain with them at all times during the installation process.
- At any time any CSC officer may require the contractor's employees to submit to a search if deemed necessary by that officer.
- Employees must be aware that a tobacco ban is in effect on CSC facilities. No smoking materials are permitted in the institution.
- Unauthorized cell phones, laptop and cameras are not permitted.

Material Requirements

Contractor must provide all personnel, tools, services, supplies, materials, supervision and equipment to complete the work as described. All material shall be new.

Requirements and Considerations

Contractor shall comply with the following:

Submittals:

- Contractor must submit shop drawings for approval prior to fabricating and ordering materials.
- Contractor must provide Material Safety Data Sheet (MSDS).
- The contractor must complete all work without delay and provide a project schedule five (5) business days after award of contract for the project authority's approval, prior to commencing work. The schedule must include the following; start date, hours of work, names of those who require entry, milestone dates and completion date.
- Contractor must submit health and safety plan (including fire emergency plan) .This plan must identify any hazards and details on how these hazards will be mitigated.
- Contractor must submit plan for the project authority's to maintain operation of the building during construction.
- The contractor's Health and Safety Plan must include the CCA COVID19 Standardized protocols for Construction Sites.
- Contractor must submit an Environmental Protection Plan that identifies tasks to be performed, associated potential risks and mitigation measures to address those risks, including addressing spill potential, risk protection and response associated with any vehicle fluids from elevating devices and delivery trucks. The contracting authority must submit a waste management plan (including a copy of waste manifests).
- The Contractor must ensure that Transportation of Dangerous Goods regulations are followed. Institution may request qualification proof for transporter.

Safety:

- The contractor must comply with all applicable Federal and Provincial safety codes.
- The contractor must maintain compliance with site procedures regarding potential hazardous work locations and situations.

Certificates, Inspections, Standards, Codes of Practice and Regulations:

- All work must comply with any applicable federal or provincial, or territorial regulations. The contractor must provide documentation confirming compliance to the project authority.
- All of the contractor's work must comply with the National Building Code or Ontario Building Code – whichever one has more stringent requirements.
- The contractor must install all new materials in accordance with manufacturer's specifications, engineering standards, building codes, and best practices.
- Contractor must submit a Notice of Project to the Ministry of Labour prior to starting the project that meets the standards set out in section 6(1) of the Regulations for Construction Projects, O.Reg 213/91 (the Regulation). The contractor must provide proof of this notification to the Project Authority prior to commencing work.

Workmanship and Housekeeping:

- Contractor must provide all necessary equipment and materials to complete the work as described in the scope of work.



- Any equipment the contractor damaged in the course of this project is to be repaired and restored to normal operation by the contractor at no cost to CSC.
- Workmanship must be of the highest standard and must meet all industry standards.
- The contractor must keep the worksite clean and neat and upon project completion the workplace area must be clean, free of post construction materials and returned to original integrity.
- If the contractor must complete work in an occupied area, then construction area must be boarded off and institutional property must be protected from damage and dust.
- Contractor is responsible for taking accurate measurements.
- The project authority, or their representative, will visually inspect all work and the work site and the contractor must complete the work and clean up the site to the satisfaction of project authority prior to project closeout.

Tool Control:

- The contractor must submit a complete tool list (tool list requires the project authority's approval prior to commencement of work) and only bring necessary tools into the institution.
- A daily tool list must be provided upon entry and all tools must be accounted for at the end of day.
- Any scrap material (including, but not limited to wiring, pipe) must accounted for and cleaned up.

Site Access:

- The contractor must perform the work during CSC's regular working hours of 0800 – 1530 Monday –Friday.
- The institution's Sally-port hours are Monday – Friday 08:15 – 15:45
- The contractor's employees must have up to date photo identification for entry into the Institution.

Additional work or delays:

- Any additional work beyond that described in this scope of work must first be approved by the project authority, and the contracting authority will include any additional work in a contract amendment prior to commencement.
- The contractor must verbally report, with a follow-up in writing, any circumstances that cause delay during the project to the Project Authority as soon as the circumstance is discovered.

Disposal or removal of materials and Environmental Protection Plan:

- The contractor must carry out disposal of any removed material using the highest standard in regards to landfill waste diversion, reusing, recycling, and comply with applicable transportation and environmental legislation (federal and provincial).

Cost Breakdown:

- Contractor shall provide a lump sum price including all material and labour.

Payments:

- Contractor will submit an invoice for all materials and labour completed from the beginning of contract to March 31, 2023 for payment. All remaining materials and labour completed between April 1, 2023 and the end of contract will be paid upon completion of the job.

Location of Work:

Collins Bay Institution,
1455 Bath Road, Kingston, Ontario Canada K7L 4V7

Period of Work:

Project shall be complete within 6 weeks of contract award.

Site Meeting

There will be an optional site visit for bidders.

Authorities

Project Authority:

Matt Boles, A/Regional Manager, Facilities Planning



Correctional Service
Canada

Service correctionnel
Canada

Contracting Authority:

Elizabeth Lake, Procurement Officer

Telephone number: 613-328-9647

E-mail: Elizabeth.lake@csc-scc.gc.ca



ANNEX D - SPECIFICATIONS

Attached are the SPECIFICATIONS for the work required.

The SPECIFICATIONS are to be referenced along with the SCOPE OF WORK – **ANNEX C** and the **DRAWINGS – ANNEX E**.

Injection Room Doors 114A/114B

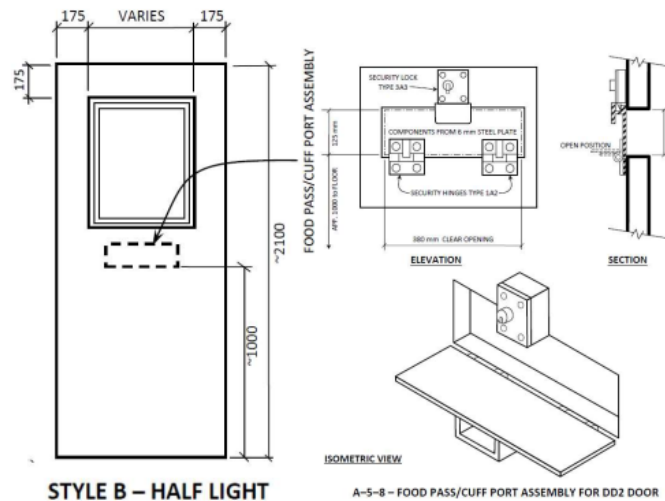

Food Pass/Cuff Port assembly required, installation to be 1000mm from bottom of door.

Detention Doors – Swing (DD1)

6.2.1 DD1 doors and frames shall have a minimum clear opening (door frame element or hardware cannot interfere with the clear opening) of 810 mm x 2100 mm, unless specified otherwise.

6.2.2 DD1 doors shall be constructed of 2.0 mm (14ga) sheet steel both sides with total thickness of 50 mm. See standard NAAMM/HMMA 863-046, specification CSI 08 34 63.13 – Steel Detention Doors and Frames (NMS 08 34 63)7 for additional details.

6.2.3 DD1 doors of type C or D using narrow lights shall have 6 mm clear tempered glass. For larger glazing panels on detention doors, follow Section A-13 Control Post, Level B.

6.2.4 DD1 doors and frames are to be constructed as required in standard NAAMM/HMMA 863-04 (see footnote 6) and specification CSI 08 34 63.13 – Steel Detention Doors and Frames (NMS 08 34 63). In addition, test reports shall be submitted from an independent testing laboratory certifying the following minimum performance of a typical Detention door, 860 x 2100 mm. Doors certified under ASTM F1450-058 are acceptable. The following tests are applicable to DD1 and DD2 doors with minor differences in deflection as noted:

6.2.4.1 Static Load: Centrally apply load of 4000 kg at quarter points on door. Maximum deflection must not exceed 30 mm (15 mm for DD2).



Permanent set not to exceed 10.0 mm (2 mm for DD2) after release of load (see Plate A-5-9).

6.2.4.2 Rack Test: Concentrate load of 2645 kg on one unsupported corner of door. Door must not fail. Deflection must not exceed 50 mm (35 mm for DD2) (see Plate A-5-10).

6.2.4.3 Impact Load Test: The door is mounted in a frame as in a normal cell setting. The door is subjected to a series of impact loads of 271 Joules following a pattern of targets from a pendulum ram (see Plate A-5-11). Impacts are delivered on the push side of the door. The number of impacts for a DD-1 and DD-2 doors are:

200 lock or strike impacts (target 1)

75 hinge impacts (targets 2, 3 & 4)

100 corner panel impacts (target 5)

6.2.4.4 The door must remain operable after the test.

6.2.5 Plate A-5-3 illustrates typical DD1 swing door details.



Injection Room Lighting

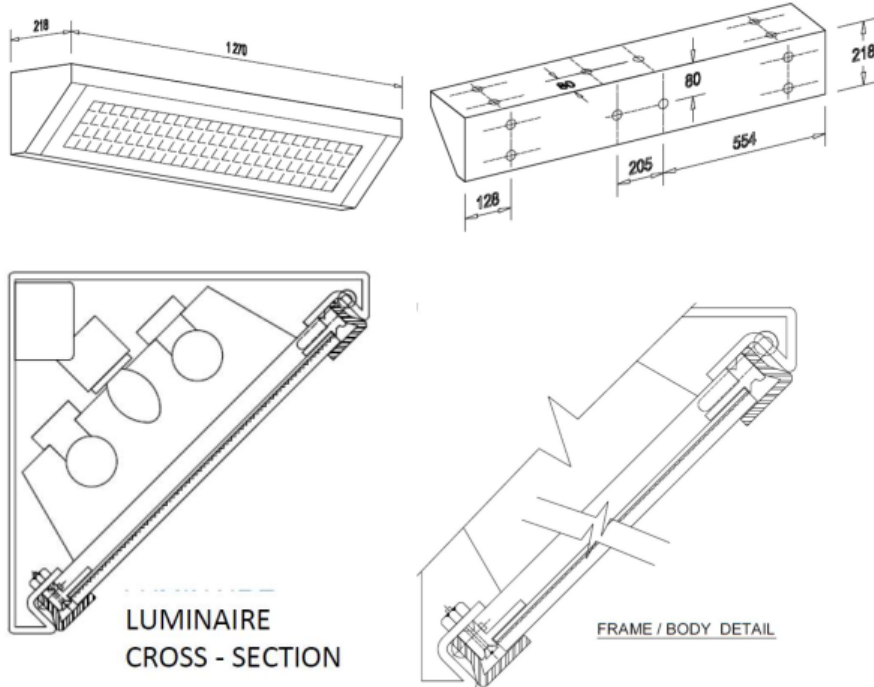

7.1 Fixture Type

Cell light fixtures may be supplied by CSC at a cost per unit to the Contractor. The fixture will be manufactured for CSC. Specify storing, installing etc. by Contractor, unless instructed by CSC otherwise.

7.2 Power Requirement

The fixture shall include a 2/32 W fluorescent lamp rapid start ballast. It shall operate on 120 VAC 60Hz on a separate circuit than receptacles. It will also have a small lamp as night light. LED strip lighting may be used instead of fluorescent.

7.3 Installation

Specify installation of fixture to suit the dimensions given in "Plate E-4-1" at end of this section.

7.4 Use

Specify use of this fixture for all medium, maximum, and multi security institutions. The fixture is to be used in all cells and similar inmate secure areas.

LEVELS OF ILLUMINATION

8.1 General

8.1.1 Lighting levels should be in accordance with Illuminating Engineering Society Handbook, Latest Edition – IESNA. Submit to CSC detail calculations of light intensities to support the design.



ANNEX E – DRAWINGS

The DRAWINGS for the work required are provided as a separate attachment.

The DRAWINGS are to be referenced along with the SCOPE OF WORK – **ANNEX C** and the SPECIFICATIONS – **ANNEX D**.



ANNEX F – CONTRACT SECURITY PROGRAM

APPLICATION FOR REGISTRATION (AFR) for Canadian legal entities

Instructions for completing the Application for Registration (AFR)

Privacy notice for Canadian entities registering in the CSP

Part of the information collected in this form includes personal information which is collected under the authority of subsection 7(1) of the *Financial Administration Act* and is mandatory in accordance with Treasury Board's *Policy on Government Security and Standard on Security Screening* for the purposes of security assessment and registration in the Contract Security Program (CSP) of Public Services and Procurement Canada (PSPC). The personal information will be used to assess your eligibility to hold a security status or security clearance and for your organization to be registered in the Contract Security Program. The information provided may be disclosed to the Royal Canadian Mounted Police and Canadian Security Intelligence Service to conduct the requisite checks and / or investigation in accordance with the *Policy on Government Security and Standard on Security Screening*. Additionally, the information may be disclosed to and used by other federal institutions that may require this information as part of their functions or investigation under Canadian Law or to the industrial security programs of foreign governments (with which Canada has bilateral security instruments) for foreign assurances.

Personal information is protected, used and disclosed in accordance with the Privacy Act and is described in the Info Source under the Personal Information Bank PWGSC PPU 015 ([Access to information and privacy - PSPC \(tpsgc-pwgsc.gc.ca\)](#)) and the TBS standard personal information bank Personal Security Screening PSU 917 ([Standard personal information banks - Canada.ca](#)). Under the *Privacy Act*, you have the right to access and correct your personal information, if erroneous or incomplete. The personal information from paper sources that accompanies an organization registration is retained for two years after the last administrative action, and then destroyed. The personal information from paper sources that accompanies a foreign ownership, control, or influence assessments is kept for two years, and then destroyed if there are no changes to the organization that are reported to the foreign ownership, control, or influence evaluation office during this period. The personal information from paper sources that accompanies the personnel security screening process or foreign assurance process will be retained for a minimum period of two years after the last administrative action, and then destroyed. The Contract Security Program's retention period and disposal standards of personal information in electronic format may vary from the above retention period.

If you have concerns or require clarification about this privacy notice, you can contact PSPC's Access to Information and Privacy Directorate by email at TPSGC.ViePrivee-Privacy.PWGSC@tpsgc-pwgsc.gc.ca. If you are not satisfied with the response to your privacy concern or if you want to file a complaint about the handling of your personal information, you may wish to contact the Office of the Privacy Commissioner of Canada.

General Instructions:

- This form is used for registering Canadian legal entities **ONLY**. The CSP does not register foreign based organizations. **ALL** Foreign based firms must contact the [International Industrial Security Directorate \(IISD\)](#) for more information on the security screening process. Canadian subsidiaries of foreign based firms may be eligible to register with the CSP.
- This form and all supporting documentation requested must be provided in English or French.
- In any instance where this form does not allow enough space for a complete answer, please include additional pages or rows to the table as required.

For organizations that do not yet have a clearance, refusal to provide required information, the provision of a false statement, misleading information, concealment or failure to disclose of any material fact on this application will result in the CSP not granting, or upgrading, a security clearance.

In the case of already cleared organizations; a denial or revocation of your organization's existing security clearance may occur and any personnel reliability statuses and/or personnel security clearances issued to your organization will be administratively closed out along with the organization's clearance with the Contract Security Program. This will immediately prohibit your eligibility to perform work on contracts requiring organization security clearances.

Section A - Business Information

- **Legal name of the organization** refers to the legal name of the organization as it is organized & existing within the country of jurisdiction. In the case of Canadian legal entities, this would be the legal name that is registered with federal, provincial or territorial authorities.
- **Business or Trade name** refers to the name which a business trades under for commercial purposes, although its registered, legal name, used for contracts and other formal situations, may be another name.
- **Type of Organization** - All required documentation in relation to the type of organization must be provided
 - **Corporation** refers to an entity having authority under the law to act as a single person distinct from the shareholders who own it and having rights to issue stock and exist indefinitely.
Provide the following information to substantiate this "Type of Organization" selection:



- Stock exchange identifier (if applicable);
 - Certificate of incorporation, compliance, continuance, current articles of incorporation, etc.
 - Ownership structure chart is mandatory
- **Partnership** refers to an association or relationship between two or more individuals, corporations, trusts, or partnerships that join together to carry on a trade or business.
Provide the following information to substantiate this "Type of Organization" selection:
- Evidence of legal status, ie. partnership agreement;
 - Provincial partnership name registration (if applicable);
 - Ownership structure chart
- **Sole proprietor** refers to the owner of a business who acts alone and has no partners.
Provide the provincial registration documentation (if applicable) ie. master business license, provincial name registration document
- **Other** (universities, financial institutions, unincorporated organizations, Assembly of First Nations, etc.)
- Provide the following information to substantiate this "Type of Organization" selection:
- Evidence of legal status such as acts, charters, bands, etc.
 - Ownership structure chart and management structure chart
- **Principal place of business** must be where the business is physically located and operating in Canada. Virtual locations, mail boxes, receiving offices, coworking spaces, representative agent's office, etc. will not be accepted.
- **Self-identify as a diverse supplier:** Public Services and Procurement Canada (PSPC) defines a diverse supplier as "a business owned or led by Canadians from underrepresented groups, such as women, Indigenous Peoples, persons with disabilities and visible minorities."

Section B - Security Officers

Identify the individual(s) you intend to nominate or are already appointed as your organization's company security officer and alternate company security officer(s). For Document Safeguarding Capability at other locations, please ensure to indicate address(site) the ACSO is located at. Add additional rows or provide a separate page as required. Employee has the same meaning as that used by the Canada Revenue Agency.

- Email address must be able to accept various types of correspondence from the CSP
- Security officers **must** meet all of the following criteria:
 - an employee of the organization;
 - physically located in Canada;
 - a Canadian citizen*; and
 - security screened at the same level as the organization (in some cases alternates may require a different level).*Canadian citizenship is required due to the oversight responsibility entrusted to a security officer and some contractual requirements in relation to national security. This requirement may be waived on a case by case basis for Permanent Residents.

Section C - Officers

- Your organization must list **all** the names and position titles for its officers, management, leadership team, executives, managing partners, authorized signatories, members, etc. that are responsible for the day to day operations of its business. A management structure chart must be provided to demonstrate the reporting structure. Add additional rows to the section if required.
- For the purposes of the Contract Security Program, the term "Country of Primary Residence/National Domicile" refers to the particular country for a person's true, fixed, principal and permanent home, to which that person intends to return and remain even though currently residing elsewhere.
- **Citizenship** refers to the status of being a citizen. A **citizen** is a person who, by either birth or naturalization, is a member of a state or nation, entitled to enjoy all the civil rights and protections of that state or nation and owing allegiance to its government.

Section D - Board of Directors

- List **all** members of your organization's board of directors. Indicate all board titles including the chairperson if there is one. Add additional rows to the section or on a separate page if required.
- For the purposes of the Contract Security Program, the term "Country of Primary Residence/National Domicile" refers to



the particular country for a person's true, fixed, principal and permanent home, to which that person intends to return and remain even though currently residing elsewhere.

- **Citizenship** refers to the status of being a citizen. A **citizen** is a person who, by either birth or naturalization, is a member of a state or nation, entitled to enjoy all the civil rights and protections of that state or nation and owing allegiance to its government.

Section E - Ownership Information

- For the purposes of the CSP, the following interpretations are applicable:
 - **Direct (or registered) ownership** are **all** owners who hold legal title to a property or asset in that owner's name.
 - **Ownership** refers to either (1) voting rights attached to the corporation's outstanding voting shares or (2) outstanding shares measured by fair market value.
 - **Parent company** refers to a company which owns and/or controls controlling interest (e.g., voting stock) of other firms or companies, usually known as subsidiaries, which may give it control of the operation of the subsidiaries.

Section F - Justification (this section is to be completed by organizations that are undergoing a renewal ONLY - not bidding)

- Your organization is to provide a list of active federal contracts, subcontracts, leases, supply arrangements (SA), standing offers (SO), purchase orders that have security requirements. Indicate the contract number (lease, SA, SO, sub-contract, etc.), contracting authority or prime contractor and the security level requirement.

Section G - Certification and Consent

- Only an officer identified in Section C may complete this section.



APPLICATION FOR REGISTRATION (AFR) for Canadian legal entities

NOTE:

The provision of false, misleading information, or concealment and/or failure to disclose of any material fact on this application will result in a denial or revocation of your organization security clearance and registration with the Contract Security Program which will immediately prohibit your eligibility to perform on contracts requiring organization security clearances. An incomplete form **will not** be processed.

SECTION A - BUSINESS INFORMATION

1. Legal name of the organization	
2. Business or trade name (if different from legal name)	
<p>3. Type of organization - Indicate the type of organization and provide the required validation documentation (select one only)</p> <p><input type="checkbox"/> Sole proprietor</p> <p><input type="checkbox"/> Partnership</p> <p><input type="checkbox"/> Corporation</p> <p style="padding-left: 40px;"><input type="checkbox"/> Private</p> <p style="padding-left: 40px;"><input type="checkbox"/> Public</p> <p><input type="checkbox"/> Other (specify)</p>	
4. Provide a brief description of your organization's general business activities.	
5. Procurement Business Number (PBN) (if applicable)	6. Self-identify as a diverse supplier (provide profile)
7. Business civic address (head office)	
8. Principal place of business (if not at head office)	
9. Mailing address (if different from business civic address)	
10. Organization website (if applicable)	
11. Telephone number	12. Facsimile number



13. Number of employees in your organization or corporate entity	14. Number of employees requiring access to protected/ classified information/assets/sites
--	--

SECTION B –SECURITY OFFICERS

Please identify all security officers for your organization. For document safeguarding capability identify the site number for each ACSO and the corresponding address for each site below.

Add additional rows or attachments as needed if there is not enough space allotted

Position title	Site #	Surname	Given name	E-mail (where the CSP will send correspondence)
Company security officer (CSO)				
Alternate company security officer (ACSO)				
ACSO (if applicable)				
ACSO (if applicable)				
ACSO (if applicable)				

For Document Safeguarding Capability ONLY:

00 – Address will be principal place of business	
01 – Site address:	
02 – Site address:	

SECTION C – OFFICERS (managing partners, key leadership, signatories, etc.)

Add additional rows or attachments as needed and include management structure chart demonstrating reporting structures

Position title - within your organization	Surname	Given name	Citizenship(s)	Country of primary residence/National domicile

SECTION D – LIST OF BOARD OF DIRECTORS

Add additional rows or attachments as needed

Position title	Surname	Given name	Citizenship(s)	Country of primary residence/National domicile



SECTION E - OWNERSHIP INFORMATION - PLEASE COMPLETE FOR EACH LEVEL OF OWNERSHIP

Please complete for each level of ownership

Identify all entities, individuals, public or private corporations that have an ownership stake in your organization being registered. Indicate if the entity has a valid Facility Security Clearance from Public Services and Procurement Canada's Contract Security Program or any other country. For publicly traded corporations, identify stock exchange. If there are more than three levels of ownership; please submit on an additional page to include **all** levels of ownership from direct to ultimate.

Note: The organization structure chart with percentages of ownership must be included with your submission

SECTION E-1 - OWNERSHIP LEVEL 1 (direct ownership) if more than three - please provide on additional sheet

Ownership - Level 1 (Direct Parent)			
Name of organization or individual			
Address			
Type of entity (e.g. private or public corporation, state-owned)			
Stock exchange identifier (if applicable)			
Facility security clearance (FSC) yes/no			
Percentage of ownership			
Country of jurisdiction or citizenship			

SECTION E-2 - OWNERSHIP LEVEL 2

If there is any additional ownership for the names listed in the previous section (E-1) please provide the information below. If not, please indicate N/A (not applicable).

Ownership of entries listed in E-1 (Level 2)			
Name of direct owner from E-1			
Name of organization or individual			



Address			
Type of entity (e.g. private or public corporation, state-owned)			
Stock exchange identifier (if applicable)			
Facility security clearance (FSC) yes/no			
Percentage of ownership			
Country of jurisdiction or citizenship			

SECTION E-3 - OWNERSHIP LEVEL 3

If there is any additional ownership for the names listed in the previous section (E-2) please provide the information below. If not, please indicate N/A (not applicable).

Ownership of entries listed in E-2 (Level 3)

Name of intermediary ownership from E-2			
Name of organization or individual			
Address			
Type of entity (e.g. private or public corporation, state-owned)			
Stock exchange identifier (if applicable)			
Facility security clearance (FSC) yes/no			
Percentage of ownership			
Country of jurisdiction or citizenship			

SECTION F - JUSTIFICATION (FOR RENEWING ORGANIZATIONS)

Add additional rows or attachments as needed

Please provide all current procurement rationales that have security requirements - i.e. contracts, leases, RFP, RFI, ITQ, supply arrangements, standing offers, etc.

Contract, lease, SA, SO, etc. number	Client / contracting authority	Security Type & level	Expiry date (dd-mm-yyyy)



SECTION G - CERTIFICATION AND CONSENT (ONLY AN OFFICER IDENTIFIED IN SECTION C MAY COMPLETE THIS SECTION)

I, the undersigned, as the Officer authorized by the organization, have read the Privacy Notice to this application and do hereby certify that the information contained in this application is true, complete and correct. I acknowledge and agree to comply with the responsibilities outlined in the Public Services and Procurement Canada's Contract Security Manual and consent to the collection, use and disclosure of my personal information for the purposes as described above. **I agree to notify the Contract Security Program of any changes to the organization including but not limited to: change of address, phone number, contact information, change in security officers, officers and directors, board members, partners, management / leadership team and ownership.**

Surname	Given name
Position title	Telephone number (include extension number if any)
Facsimile number	Email address
Signature	Date (dd-mm-yyyy)

FOR USE BY THE PSPC'S CONTRACT SECURITY PROGRAM

Recommendations	
Recommended by e-signature	Approved by e-signature