



National Defence

Défense nationale

National Defence Headquarters
Ottawa, Ontario
K1A 0K2

Quartier général de la Défense nationale
Ottawa (Ontario)
K1A 0K2

REQUEST FOR PROPOSAL DEMANDE DE PROPOSITION

RETURN BIDS TO: RETOURNER LES SOUMISSIONS À :

Bid Receiving Mailbox – Réception des soumissions

Email – Courriel:

aops.pfm-npea.cp@forces.gc.ca

Stephen.Vogler@forces.gc.ca

Proposal To: National Defence Canada

We hereby offer to sell to His Majesty the King in right of Canada, in accordance with the terms and conditions set out herein, referred to herein or attached hereto, the goods and services listed herein and on any attached sheets at the price(s) set out therefore.

Proposition à : Défense nationale Canada

Nous offrons par la présente de vendre à Sa Majesté la Reine du chef du Canada, aux conditions énoncées ou incluses par référence dans la présente et aux annexes ci-jointes, les biens et services énumérés ici et sur toute feuille ci-annexée, au(x) prix indique(s).

Title/Titre Towing Gear	Solicitation No – N° de l'invitation W847S-240146/B
Date of Solicitation – Date de l'invitation December 28, 2023	
Address Enquiries to – Adresser toutes questions à Contracting Authority: Name: Steve Vogler PMO AOPS DGMPD(Sea) Halifax, NS B3K 5X5	
Telephone No. – N° de téléphone 902-456-6702	Email – Courriel Stephen.Vogler@forces.gc.ca
Destination : Thales Warehouse 495 Wilkinson Ave Dartmouth, NS B3B 0M6	

Instructions:

Municipal taxes are not applicable. Unless otherwise specified herein all prices quoted must include all applicable Canadian customs duties, GST/HST, excise taxes and are to be delivered Delivery Duty Paid including all delivery charges to destination(s) as indicated. The amount of the Goods and Services Tax/Harmonized Sales Tax is to be shown as a separate item.

Instructions :

Les taxes municipales ne s'appliquent pas. Sauf indication contraire, les prix indiqués doivent comprendre les droits de douane canadiens, la TPS/TVH et la taxe d'accise. Les biens doivent être livrés « rendu droits acquittés », tous frais de livraison compris, à la ou aux destinations

Solicitation Closes – L'invitation prend fin

At – à: 2:00 PM AST – Eastern Daylight Time –
Heure avancée de l'Est On – January 12, 2023
– le Janvier 12, 2024

Delivery required - Livraison exigée See Herein	Delivery offered - Livraison proposée
Vendor Name and Address - Raison sociale et adresse du fournisseur	
Name and title of person authorized to sign on behalf of vendor (type or print) - Nom et titre de la personne autorisée à signer au nom du fournisseur (caractère d'imprimerie)	
Name/Nom	Title/Titre
Signature	Date

PART 1 - GENERAL INFORMATION

- 1.1 This bid solicitation cancels and supersedes previous bid solicitation number W847S-240146/A dated 2023-08-11 with a closing of 2023-10-05 at 2:00 p/m (EST). A debriefing or feedback session will be provided upon request to bidders/offerors/suppliers who bid on the previous solicitation**
- 1.2 Security Requirements**
There is no security requirement associated with this bid solicitation.
- 1.3 Statement of Requirements** The statement of requirements is detailed under the "Statement of Requirements" in Annex "A".

Debriefings

Bidders may request a debriefing on the results of the bid solicitation process. Bidders should make the request to the Contracting Authority within 15 working days from receipt of the results of the bid solicitation process. The debriefing may be in writing, by telephone or in person.

1.4 Trade Agreements

The requirement is subject to the provisions of the Canadian Free Trade Agreement (CFTA).

1.5 Canada Post Corporation's (CPC) Connect service.

This bid solicitation allows bidders to use the CPC Connect service provided by Canada Post Corporation to transmit their bid electronically. Bidders must refer to Part 2 entitled Bidder Instructions, and Part 3 entitled Bid Preparation Instructions, of the bid solicitation, for further information.

PART 2 - BIDDER INSTRUCTIONS

2.1 Standard Instructions, Clauses and Conditions

All instructions, clauses and conditions identified in the bid solicitation by number, date and title are set out in the **Standard Acquisition Clauses and Conditions Manual** (<https://buyandsell.gc.ca/policy-andguidelines/standard-acquisition-clauses-and-conditions-manual>) issued by Public Works and Government Services Canada.

Bidders who submit a bid agree to be bound by the instructions, clauses and conditions of the bid solicitation and accept the clauses and conditions of the resulting contract.

The **2003** Date: 2023-06-08 Standard Instructions - Goods or Services - Competitive Requirements, are incorporated by reference into and form part of the bid solicitation.

2.1.2 SACC Manual Clauses

2.1.3 Technical Difficulties of Bid Transmission

Despite anything to the contrary in (05), (06) or (08) of the Standard Instructions, where a Bidder has commenced transmission of its bid through an electronic submission method (such as facsimile or Canada Post Corporation's (CPC) Connect service, or other online service) in advance of the bid solicitation closing date and time, but due to technical difficulties, Canada was unable to receive or decode the entirety of the Bid by the deadline, Canada may nonetheless accept the entirety of the Bid received after the bid solicitation closing date and time, provided that the Bidder can demonstrate the following:

- (i) The bidder contacted Canada in advance of the bid solicitation closing date and time to attempt to resolve its technical difficulties; OR
- (ii) The electronic properties of the Bid documentation clearly indicate that all components of the Bid were prepared in advance of the bid solicitation closing date and time.

2.1.4 Completeness of the Bid

After the closing date and time of this bid solicitation, Canada will examine the Bid to determine completeness. The review for completeness will be limited to identifying whether any information submitted as part of the bid can be accessed, opened, and/or decoded. This review does not constitute an evaluation of the content, will not assess whether the Bid meets any standard or is responsive to all solicitation requirements but will be solely limited to assessing completeness. Canada will provide the Bidder with the opportunity to submit information found to be missing or incomplete in this review within two business days of notice.

Specifically, the bid will be reviewed and deemed to be complete when the following elements have been submitted by the bidder:

1. That certifications and securities required at bid closing are included.
2. That bids are properly signed, that the bidder is properly identified.

-
3. Acceptance of the terms and conditions of the bid solicitation and resulting contract.
 4. That all documents created prior to bid closing but due to technical difficulties Canada was unable to receive them, have been properly submitted and received by Canada.

5. All

certifications, declarations and proofs created prior to bid closing but due to technical difficulties Canada was unable to receive them, have been properly submitted and received by Canada

2.2 Submission of Bids

Unless otherwise specified in the bid solicitation or directed by the Contracting Authority /Procurement Authority, bids must be received by the Contracting Authority / Procurement Authority by electronic mail by the date and time indicated on the cover page of the bid solicitation.

ELECTRONIC SUBMISSIONS: Individual e-mails five (5) megabytes, or those that include other factors such as embedded macros and/or links, may be rejected by Canada's e-mail system and/or firewall (s) without notice to the Bidder or Contracting Authority / Procurement Authority. Larger bids may be submitted through more than one (1) e-mail. The Contracting Authority / Procurement Authority will confirm receipt of documents. It is the Bidder's responsibility to ensure that the Contracting Authority / Procurement Authority has received the entire submission. Bidders should not assume that all documents have been received unless the Contracting Authority / Procurement Authority confirms receipt of each document. In order to minimize the potential for technical issues, Bidders are requested to allow sufficient time before the closing date and time to confirm receipt. Technical and financial documents received after the closing date and time will not be accepted. Due to the nature of the bid solicitation, bids transmitted by facsimile will not be accepted.

2.3 Enquiries - Bid Solicitation

All enquiries must be submitted in writing to the Contracting Authority no later than 3 calendar days before the bid closing date. Enquiries received after that time may not be answered.

Bidders should reference as accurately as possible the numbered item of the bid solicitation to which the enquiry relates. Care should be taken by Bidders to explain each question in sufficient detail in order to enable Canada to provide an accurate answer. Technical enquiries that are of a proprietary nature must be clearly marked "proprietary" at each relevant item. Items identified as "proprietary" will be treated as such except where Canada determines that the enquiry is not of a proprietary nature. Canada may edit the question(s) or may request that the Bidder do so, so that the proprietary nature of the question(s) is eliminated, and the enquiry can be answered to all Bidders. Enquiries not submitted in a form that can be distributed to all Bidders may not be answered by Canada.

2.3 Applicable Laws

Any resulting contract must be interpreted and governed, and the relations between the parties determined, by the laws in force in Ontario.

Bidders may, at their discretion, substitute the applicable laws of a Canadian province or territory of their choice without affecting the validity of their bid, by deleting the name of the Canadian province or territory specified and inserting the name of the Canadian province or territory of their choice. If no change is made, it acknowledges that the applicable laws specified are acceptable to the Bidders.

2.4 Bid Challenge and Recourse Mechanisms

- (a) Several mechanisms are available to potential suppliers to challenge aspects of the procurement process up to and including contract award.
- (b) Canada encourages suppliers to first bring their concerns to the attention of the Contracting

Authority. Canada's [Buy and Sell](#) website, under the heading "[Bid Challenge and Recourse Mechanisms](#)" contains information on potential complaint bodies such as:

- Office of the Procurement Ombudsman (OPO)
 - Canadian International Trade Tribunal (CITT)
- (c) Suppliers should note that there are **strict deadlines** for filing complaints, and the time periods vary depending on the complaint body in question. Suppliers should therefore act quickly when they want to challenge any aspect of the procurement process.

PART 3 - BID PREPARATION INSTRUCTIONS

3.1 Bid Preparation Instructions

Canada requests that bidders provide their bid in separately bound sections as follows:

Section I: Technical Bid: one (1) soft copy submitted by e-mail;

Section II: Financial Bid: one (1) soft copy submitted by e-mail;

Section III: Certifications: one (1) soft copy submitted by e-mail; and

Section IV: Additional Information: one (1) soft copy submitted by e-mail.

Prices must appear in the financial bid only. No Prices must be indicated in any other section of the bid. Canada requests that Bidders follow the format instructions described below in the preparation of their bid:

- (a) use 8.5 x 11 inch (216 mm x 279 mm) paper;
- (b) use a numbering system that corresponds to the bid solicitation.
- (c) include a title page at the front of each volume of the bid that includes the title, date, bid solicitation number, bidder's name and address and contact information of its representative; and
- (d) Include a table of contents.
- (e) Soft copies will be accepted in any of the following electronic formats:
 - Portable Document Format .pdf
 - Microsoft Word 97/2003 (.doc)
 - Microsoft Excel 97/2003 (.xls)

Submission of Only One Bid: A Bidder, including related entities, will be permitted to submit only one bid in response to this bid solicitation. If a Bidder or any related entities participate in more than one bid (participating means being part of the Bidder, not being a subcontractor), Canada will provide those Bidders with two (2) working days to identify the single bid to be considered by Canada. Failure to meet this deadline will result in all the affected bids being disqualified.

For the purposes of this Article, regardless of the jurisdiction where any of the entities concerned is incorporated or otherwise formed as a matter of law (whether that entity is a natural person, corporation, partnership, etc), an entity will be considered to be "related" to a Bidder if:

- a) they are the same legal entity (i.e., the same natural person, corporation, partnership, limited liability partnership, etc.);
- b) they are "related persons" or "affiliated persons" according to the *Canada Income Tax Act*;
- c) the entities have now or in the two years before bid closing had a fiduciary relationship with one another (either as a result of an agency arrangement or any other form of fiduciary relationship); or
- d) the entities otherwise do not deal with one another at arm's length, or each of them does not deal at arm's length with the same third party.
- e) Individual members of a joint venture cannot participate in another bid, either by

submitting a bid alone or by participating in another joint venture.

Section I: Technical Bid

In their technical bid, Bidders should explain and demonstrate how they propose to meet the requirements and how they will carry out the Work.

Section II: Financial Bid

Bidders must submit their financial bid in accordance with the table provided in "Annex C- Basis of Payment."

Section III: Certifications

In Section III of their bid, Bidders should submit the certifications and additional information required under Part 5.

Section IV: Additional Information

1. their legal name;
2. their Procurement Business Number (PBN);
3. the name of the contact person (provide also this person's mailing address, phone and facsimile numbers and email address) authorized by the Bidder to enter into communications with Canada with regards to their bid, and any contract that may result from their bid;
4. for Part 2, article 2.3, Former Public Servant, of the bid solicitation: the required answer to each question; and, if the answer is yes, the required information;
5. for Part 6, article 6.1, Security Requirement, of the bid solicitation:
 - a) for each individual who will require access to classified or protected information, assets or sensitive work sites:
 - 1) the name of the individual;
 - 2) the date of birth of the individual; and
 - 3) if available, information confirming the individual meets the security requirement as indicated in Part 7 - Resulting Contract Clauses;

3.1.2 Electronic Payment of Invoices – Bid

If you are willing to accept payment of invoices by Electronic Payment Instruments, complete Annex "D" Electronic Payment Instruments, to identify which ones are accepted.

If Annex "D" Electronic Payment Instruments is not completed, it will be considered as if Electronic Payment Instruments are not being accepted for payment of invoices.

Acceptance of Electronic Payment Instruments will not be considered as an evaluation criterion.

3.1.3 Exchange Rate Fluctuation

C3010T 2014-11-27, Exchange Rate Fluctuation Risk Mitigation

PART 4 - EVALUATION PROCEDURES AND BASIS OF SELECTION

4.1 Evaluation Procedures

- (a) Bids will be assessed in accordance with the entire requirement of the bid solicitation including "technical" & "financial" evaluation criteria.
- (b) An evaluation team composed of representatives of Canada will evaluate the bids.
- (c) The evaluation team will determine if there are two (2) or more bids with a valid Canadian content certification with the bids coming from two or more Bidders that are not affiliated within the meaning used in the Competition Act, R.S.C., 1985, c. C-34. In that event, only those bids with a valid certification will be eligible to be awarded a contract; otherwise, all bids will be eligible. If at any point in the evaluation process it is found, whether by determination of invalidity of certifications, determination that bids are non-responsive or withdrawal of bids by Bidders, that there are no longer two (2) or more responsive bids with a valid certification, then all responsive bids will be eligible to be awarded a contract. Canada may conduct the validation of Canadian content certifications at any time in the evaluation process including doing so concurrently with other steps.

4.1.2 Technical Evaluation

4.1.1.1 Mandatory Technical Criteria

Bidders must be compliant with Item Requirements and Drawings provided in "Annex A – Statement of Requirement".

4.1.3 Financial Evaluation

The price of the bid will be evaluated in Canadian dollars, Applicable Taxes excluded, FOB destination, Canadian customs duties and excise taxes included.

4.2 Basis of Selection

A bid must comply with all requirements of the bid solicitation to be declared responsive. The responsive bid with the lowest evaluated price will be recommended for award of a contract.

PART 5 – CERTIFICATIONS AND ADDITIONAL INFORMATION

Bidders must provide the required certifications and additional information to be awarded a contract.

The certifications provided by Bidders to Canada are subject to verification by Canada at all times. Unless specified otherwise, Canada will declare a bid non-responsive, or will declare a contractor in default if any certification made by the Bidder is found to be untrue whether made knowingly or unknowingly, during the bid evaluation period or during the contract period.

The Contracting Authority will have the right to ask for additional information to verify the Bidder's certifications. Failure to comply and to cooperate with any request or requirement imposed by the Contracting Authority will render the bid non-responsive or constitute a default under the Contract.

5.1 Certifications Required with the Bid

Bidders must submit the following duly completed certifications as part of their bid.

- a. The Towing Gear must be manufactured by approved procedures at works approved by Lloyds Register or A.B.S. Certification. Testing is to be in accordance with Ch 10 of the Lloyd's Register Rules for Manufacture, Testing and Certification of Materials or commensurate IACS member rules and regulations. Loose gear must have a Safe Working Load of not less than 863.75 Kn.
- b. Classification Society Type Approval Certification.
- c. Materiel Forging Certificates.
- d. Load test certificates bearing a professional engineer's seal that conform to the requirements in IACS Unified Requirements A (IACS UR A) for mooring, anchoring, and towing.

5.1.2 Integrity Provisions - Declaration of Convicted Offences

In accordance with the Integrity Provisions of the Standard Instructions, all bidders must provide with their bid, **if applicable**, the declaration form available on the [Forms for the Integrity Regime](http://www.tpsgc-pwgsc.gc.ca/ci-if/declaration-eng.html) website (<http://www.tpsgc-pwgsc.gc.ca/ci-if/declaration-eng.html>), to be given further consideration in the procurement process.

5.1.3 Additional Certifications Required with the Bid

- Bidders must be Compliant with Certification requirements in Annex "B"

5.2 Certifications Precedent to Contract Award and Additional Information

The certifications and additional information listed below should be submitted with the bid but may be submitted afterwards. If any of these required certifications or additional information is not completed and submitted as requested, the Contracting Authority will inform the Bidder of a time frame within which to provide the information. Failure to provide the certifications or the additional information listed below within the time frame provided will render the bid non-responsive.

5.2.1 Integrity Provisions – Required Documentation

In accordance with the section titled Information to be provided when bidding, contracting or entering into a real property agreement of the [Ineligibility and Suspension Policy](http://www.tpsgc-pwgsc.gc.ca/ciif/politique-policy-eng.html) (<http://www.tpsgc-pwgsc.gc.ca/ciif/politique-policy-eng.html>), the Bidder must provide the required documentation, as applicable, to be given further consideration in the procurement process.

5.2.2 Federal Contractors Program for Employment Equity - Bid Certification

By submitting a bid, the Bidder certifies that the Bidder, and any of the Bidder's members if the Bidder is a Joint Venture, is not named on the Federal Contractors Program (FCP) for employment equity "FCP Limited Eligibility to Bid" list available at the bottom of the page of the [Employment and Social Development Canada \(ESDC\) - Labour's](#) website.

Canada will have the right to declare a bid non-responsive if the Bidder, or any member of the Bidder if the Bidder is a Joint Venture, appears on the "FCP Limited Eligibility to Bid" list at the time of contract award.

Canada will also have the right to terminate the Contract for default if a Contractor, or any member of the Contractor if the Contractor is a Joint Venture, appears on the "[FCP Limited Eligibility to Bid](#)" list during the period of the Contract.

The Bidder must provide the Contracting Authority with a completed annex titled [Federal Contractors Program for Employment Equity - Certification](#), before contract award. If the Bidder is a Joint Venture, the Bidder must provide the Contracting Authority with a completed annex Federal Contractors Program for Employment Equity - Certification, for each member of the Joint Venture.

PART 6 - RESULTING CONTRACT CLAUSES

The following clauses and conditions apply to and form part of any contract resulting from the bid solicitation.

6.1 Security Requirements

6.1. There is no security requirement applicable to the Contract.

6.2 Standard Clauses and Conditions

All clauses and conditions identified in the Contract by number, date and title are set out in the [Standard Acquisition Clauses and Conditions Manual](https://buyandsell.gc.ca/policy-and-guidelines/standardacquisition-clauses-and-conditions-manual) (<https://buyandsell.gc.ca/policy-and-guidelines/standardacquisition-clauses-and-conditions-manual>) issued by Public Works and Government Services Canada.

6.3 General Conditions

[2010A](#) 2022-12-01 - General Conditions - Goods (Medium Complexity), apply to and form part of the Contract.

6.4 Period of the Contract

The period of the contract is from date of Contract to ____ (insert date at contract award).

6.5 Optional Goods and/or Services

The Contractor grants to Canada the irrevocable option to acquire the additional goods, services or both described at "Annex A – Statement of Requirements" of the Contract under the same conditions and at the prices and/or rates stated in the Contract in "Annex C – Basis of Payment." The option may only be exercised by the Contracting Authority and will be evidenced, for administrative purposes only, through a contract amendment. The Contracting Authority may exercise the option at any time before the expiry of the Contract by sending a written notice to the Contractor.

6.6 Delivery Date

The firm quantity deliverables must be received on or before ____ (insert date). The delivery date for the optional additional quantities will be discussed with contractor.

6.6.1 Delivery Points

Goods must be consigned and delivered to the destination specified below:

Thales Warehouse - 495 Wilkinson Ave, Dartmouth, NS B3B 0M

6.7 Authorities

6.7.1 Contracting Authority

The Contracting Authority for the Contract is:

Name: Stephen Vogler
Title: Procurement and Finance Manager
Department of National Defence / Government of Canada
E-mail address: Stephen.Vogler@forces.gc.ca

The Contracting Authority is responsible for the management of the Contract and any changes to the Contract must be authorized in writing by the Contracting Authority. The Contractor must not perform work in excess of or outside the scope of the Contract based on verbal or written requests or instructions from anybody other than the Contracting Authority.

6.7.2 Technical Authority (to be inserted at contract award)

The Technical Authority for the Contract is:

Name: _____
Title: _____
Organization: _____
Address: _____
Telephone : _____
Facsimile: _____
E-mail address: _____

The Technical Authority is the representative of the department or agency for whom the Work is being carried out under the Contract and is responsible for all matters concerning the technical content of the Work under the Contract. Technical matters may be discussed with the Technical Authority, however the Technical Authority has no authority to authorize changes to the scope of the Work. Changes to the scope of the Work can only be made through a contract amendment issued by the Contracting Authority.

6.7.3 Contractor's representative (to be inserted at contract award):

The Contractor's Representative for the Contract is: [to be inserted at contract award]

Name: _____
Title: _____
Organization: _____
Address: _____
Telephone: ----- _____
Facsimile: ----- _____
E-mail address: _____

6.8 Payment

6.8.1 Basis of Payment

In consideration of the Contractor satisfactorily completing all of its obligations under the Contract, the Contractor will be paid firm unit prices, as specified in "Annex C – Basis of Payment" totaling _____(insert at contract award) in Canadian Dollars, Customs duties included, and Applicable Taxes extra.

6.8.2 Invoice Instructions

1. Invoices must be distributed as follows:

One (1) copy must be forwarded to the Contracting Authority identified under the section entitled "Authorities" of the Contract.

6.9 Certifications and Additional Information

6.9.1 Compliance

Unless specified otherwise, the continuous compliance with the certifications provided by the Contractor in its bid or precedent to contract award, and the ongoing cooperation in providing additional information are conditions of the Contract and failure to comply will constitute the Contractor in default. Certifications are subject to verification by Canada during the entire period of the Contract.

6.9.2 Condition of Material

The Contractor must provide material that is new production of current manufacture supplied by the principal manufacturer or its accredited agent. The material must conform to the latest issue of the applicable drawing, specification and part number, as applicable, that was in effect on the bid closing date as per Requirements in Annex A and Certification in Annex B.

7.0 Applicable Laws

The Contract must be interpreted and governed, and the relations between the parties determined, by the laws in force in Ontario.

8.0 Priority of Documents

If there is a discrepancy between the wording of any documents that appear on the list, the wording of the document that first appears on the list has priority over the wording of any document that subsequently appears on the list.

- (a) the Articles of Agreement;
- (b) the general conditions 2010A (2022-12-01),
General Conditions - Goods (Medium Complexity);
- (c) Annex A, Statement of Requirement;
- (d) Annex B, Certification Requirements;
- (e) Annex C, Basis of Payment;
- (e) Annex D Electronic Payment Instruments
- (f) the Contractor's bid dated (To be inserted upon contract award).

9.0 Defence Contract

SACC *Manual* clause [A9006C](#) 2012-07-16 - Defence Contract

10.0 Dispute Resolution

- (a) The parties agree to maintain open and honest communication about the Work throughout and after the performance of the contract.

- (b) The parties agree to consult and co-operate with each other in the furtherance of the contract and promptly notify the other party or parties and attempt to resolve problems or differences that may arise.
- (c) If the parties cannot resolve a dispute through consultation and cooperation, the parties agree to consult a neutral third party offering alternative dispute resolution services to attempt to address the dispute.
- (d) Options of alternative dispute resolution services can be found on Canada's Buy and Sell website under the heading "[Dispute Resolution](#)".

ANNEX "A"

STATEMENT OF REQUIREMENT

Item	Description	Unit of Issue	Firm Quantity	Optional Quantities	Destination Address	Invoice Address	Security Requirement	Quality Assurance Code (QAC)	Controlled Goods (CTAT or ITAR)	Trade Agreement
001	NSN: 2020-20-A0V-2127 Item Name: SHACKLE, TOWING NCAGE: LOB97 P/N: APA-TE-003 OR EQUIVALENT If offering an equivalent specify: P/N offered: NCAGE: Name of Manufacturer:	EA	4	8	Thales Warehouse 495 Wilkinson Avenue Dartmouth, Nova Scotia B2B 0B6 Canada	HMCS Sackville Bldg PO Box 99000 Stn Forces Halifax, Nova Scotia B3K SXS Canada Attn: Stephen Vogler Stephen.Vogler@forces.gc.ca	No	C	No	CFTA
002	NSN: 2020-20-A0Z-5572 Name: SENHOUSE SLIP NCAGE: LOB97 P/N: P3886S OR EQUIVALENT If offering an equivalent specify: P/N offered: NCAGE: Name of Manufacturer:	EA	2	4	Thales Warehouse 495 Wilkinson Avenue Dartmouth, Nova Scotia B2B 0B6 Canada	HMCS Sackville Bldg PO Box 99000 Stn Forces Halifax, Nova Scotia B3K SXS Canada Attn: Stephen Vogler Stephen.Vogler@forces.gc.ca	No	C	No	CFTA
003	NSN: 2020-20-A0V-2128 Item Name: SHACKLE, BALD ANCHOR NCAGE: LOB97 P/N: APA-TE-004 OR EQUIVALENT If offering an equivalent specify: P/N offered: NCAGE: Name of Manufacturer:	EA	8	16	Thales Warehouse 495 Wilkinson Avenue Dartmouth, Nova Scotia B2B 0B6 Canada	HMCS Sackville Bldg PO Box 99000 Stn Forces Halifax, Nova Scotia B3K SXS Canada Attn: Stephen Vogler Stephen.Vogler@forces.gc.ca	No	C	No	CFTA
004	NSN: 2040-20-A0V-2129 Item Name: LINK, NATO NCAGE: LOB97 P/N: APA-TE-005 OR EQUIVALENT If offering an equivalent specify: P/N offered: NCAGE: Name of Manufacturer:	EA	4	8	Thales Warehouse 495 Wilkinson Avenue Dartmouth, Nova Scotia B2B 0B6 Canada	HMCS Sackville Bldg PO Box 99000 Stn Forces Halifax, Nova Scotia B3K SXS Canada Attn: Stephen Vogler Stephen.Vogler@forces.gc.ca	No	C	No	CFTA

005	<p>NSN: 2030-20-A0V-2153 Item Name: BLAKE SLIP, CENTRE NCAGE: L0B97 P/N: APA-TE-006 OR EQUIVALENT If offering an equivalent specify: P/N offered: NCAGE: Name of Manufacturer:</p>	EA	2	4	<p>Thales Warehouse 495 Wilkinson Avenue Dartmouth, Nova Scotia B2B 0B6 Canada</p>	<p>HMCS Sackville Bldg PO Box 99000 Stn Forces Halifax, Nova Scotia B3K SXS Canada Attn: Stephen Vogler Stephen.Vogler@forces.gc.ca</p>	No	C	No	CFTA
006	<p>NSN: 2020-20-A0V-2155 Item Name: SHACKLE.KENTER NCAGE: L0B97 P/N: APA-TE-006-7 OR EQUIVALENT If offering an equivalent specify: P/N offered: NCAGE: Name of Manufacturer:</p>	EA	8	16	<p>Thales Warehouse 495 Wilkinson Avenue Dartmouth, Nova Scotia B2B 0B6 Canada</p>	<p>HMCS Sackville Bldg PO Box 99000 Stn Forces Halifax, Nova Scotia B3K SXS Canada Attn: Stephen Vogler Stephen.Vogler@forces.gc.ca</p>	No	C	No	CFTA
007	<p>NSN: 2020-20-A10-2509 Item Name: TOWING PENDANT NCAGE: L0B97 P/N: L4010010012707 OR EQUIVALENT If offering an equivalent specify: P/N offered: NCAGE: Name of Manufacturer:</p>	EA	4	8	<p>Thales Warehouse 495 Wilkinson Avenue Dartmouth, Nova Scotia B2B 0B6 Canada</p>	<p>HMCS Sackville Bldg PO Box 99000 Stn Forces Halifax, Nova Scotia B3K SXS Canada Attn: Stephen Vogler Stephen.Vogler@forces.gc.ca</p>	No	C	No	CFTA

HARRY DEWOLF CLASS TOWING GEAR

The HDW Class Towing arrangement is as shown in **Figure 1**.

Description	Specification	Approximate Dimensions	Reference
Item Name: SHACKLE, TOWING	SWL: 691 kN MBL: 1680 kN	200mm x 300mm x 400mm	<i>Figure 2</i>
Item Name: SENHOUSE SLIP	SWL: 691 kN MBL: 1680 kN	800mm x 200mm x 300mm	<i>Figure 3</i>
Item Name: SHACKLE, BALDT ANCH	SWL: 1422 kN MBL: 2035 kN	100mm x 300mm x 400mm	<i>Figure 7</i>
Item Name: LINK, NATO	SWL: 1246 kN MBL: 3114 kN	100mm x 300mm x 465mm	<i>Figure 9</i>
Item Name: BLAKE SLIP, CENTRE	SWL: 691 kN MBL: 1680 kN	2900mm x 200mm x 150mm	<i>Figure 10</i>
Item Name: SHACKLE KENTER	SWL: 1422 kN MBL: 2035 kN	150mm x 110mm x 70mm	<i>Figure 11</i>
Item Name: TOWING PENDANT	MBL: 814 kN	12500mm x 36mm	<i>Figure 12</i>

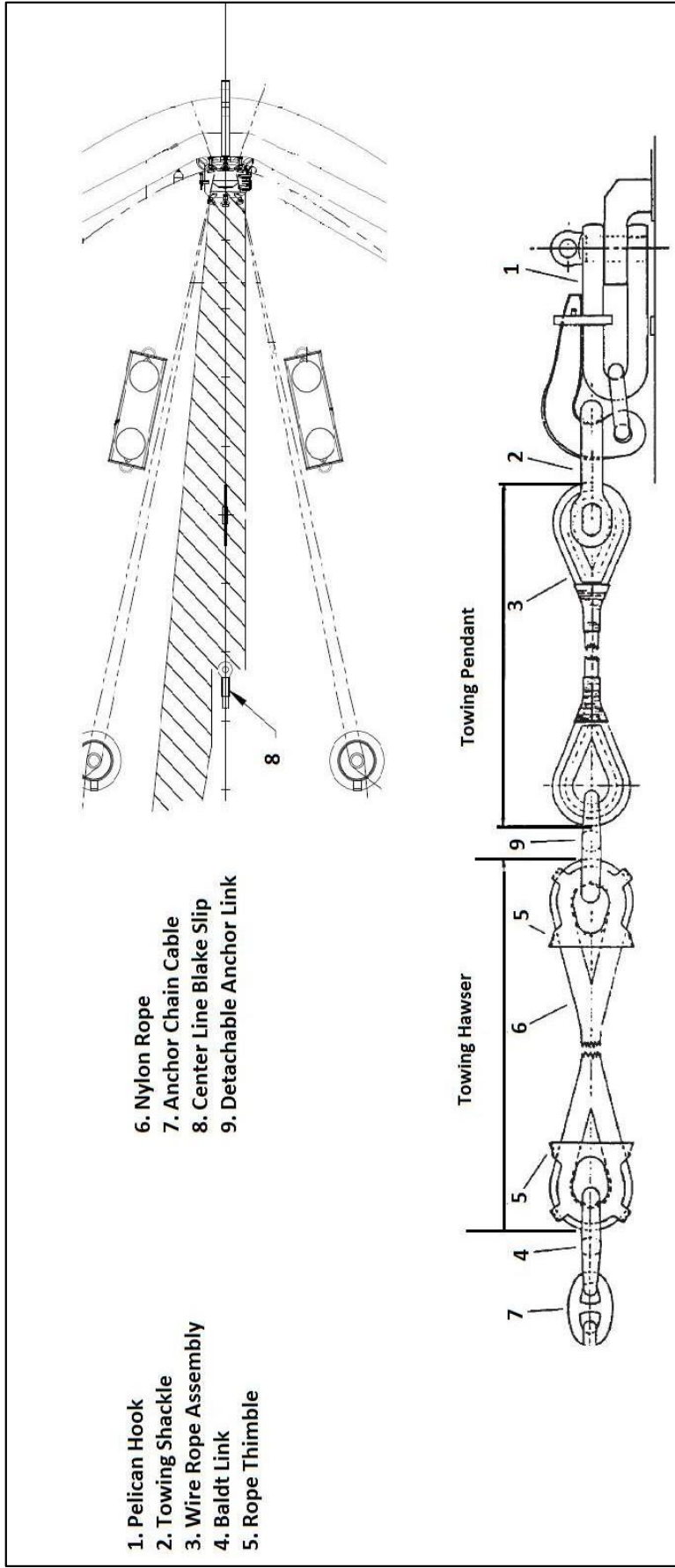
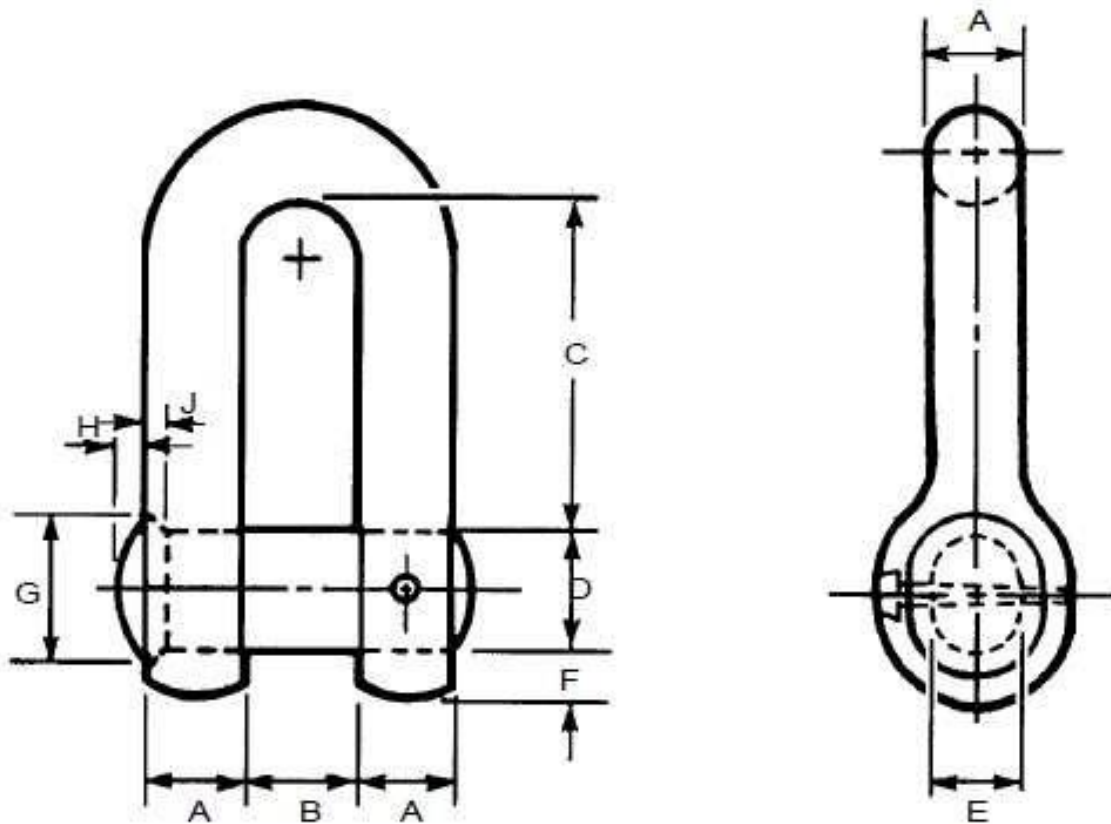
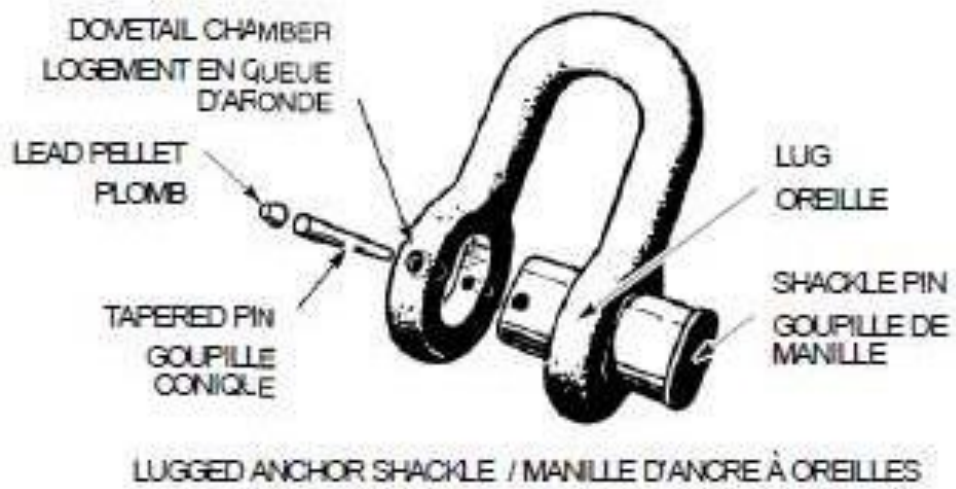

Figure 1: HDW Class Aft Towing Arrangement (Ref. B)



See Figure 4, Figure 5, and Figure 6 for Dimensions of Pin, Lead Pellet and Dovetail

A	B	C	D	E	F	G	H	J	Dia. Pin at Point	Appropriate Size of Slip
2 3/4"	3 3/4"	11 1/2"	4"	2 3/8"	1 1/2"	5"	1/2"	1/2"	1/2"	2-1/8" - 2-1/4"

Figure 2: Towing Shackle (Ref. A)

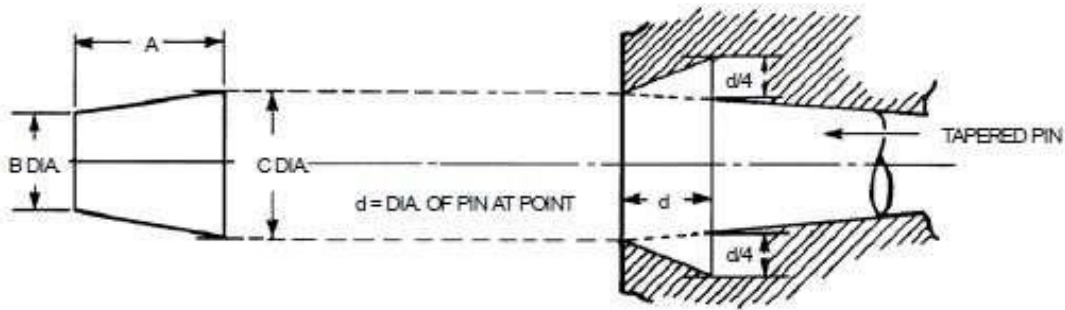

DIAGRAM OF TYPICAL LEAD PELLETT – SEE TABLES BELOW

ENLARGED DETAIL OF DOVETAIL CHAMBER IN ALL TYPES OF SHACKLES

LEAD PELLETT SHOULD BE ENTERED LARGE END FIRST AND WELL CAULKED IN

LEAD PELLETT FOR LUGLESS, ANCHOR AND JOINING SHACKLES						PELLETT FOR CLENCH SHACKLES, BUOY SHACKLES AND ALL LUGGED TYPE						
NOM. SIZE OF CABLE			INCHES			NOM. SIZE OF CABLE				INCHES		
			A	B	C					A	B	C
1	AND UNDER	1-1/4	15/16	3/8	0.47	3/8	TO	5/8	3/8	5/32	0.15	
1-1/4	AND UNDER	1-1/2	1	1/2	0.58	11/16	TO	1	9/16	5/16	0.35	
1-1/2	AND UNDER	1-3/4	1-1/16	5/8	0.70	1-1/16	TO	1-5/16	21/32	3/8	0.42	
1-3/4	AND UNDER	2	1-5/16	11/16	0.82	1-3/8	TO	1-3/4	7/8	17/32	0.59	
2	AND UNDER	2-1/4	1-13/32	13/16	0.93	1-7/8	TO	2-3/16	1-1/32	11/16	0.79	
2-1/4	AND UNDER	2-1/2	1-1/2	15/16	1.05	2-1/4	TO	2-7/16	1-1/8	3/4	0.86	
2-1/2	AND UNDER	2-3/4	1-23/32	1	1.17	2-1/2	TO	2-15/16	1-3/8	29/32	1.02	
2-3/4	AND UNDER	2-15/16	1-25/32	1-1/8	1.29	3	TO	3-1/2	1-3/8	31/32	1.10	
2-15/16	AND UNDER	3-1/8	1-7/8	1-7/32	1.37	3-3/4	TO	4	1-1/2	1-3/16	1.35	
3-1/8	AND UNDER	3-3/8	1-29/32	1-5/16	1.46							
3-3/8	AND UNDER	3-5/8	2-1/8	1-3/8	1.58							

Figure 4: Dimensions of Lead Pellets and Proportions of Dovetail Chambers (Ref. A)

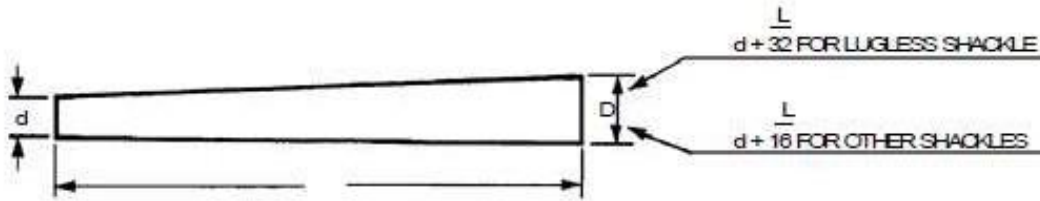

d = DIA. AT POINT OF PIN
 L = LENGTH OF PIN
 D = NOMINAL SIZE OF CABLE FOR WHICH SHACKLE IS INTENDED

PROPORTIONS OF RETAINING TAPERED PINS (INCHES)				
FOR USE WITH	d	L		TAPER
LUGLESS JOINING SHACKLE	0.35D	3.40D		1 IN 32
LUGLESS ANCHOR SHACKLE	0.35D	5.0 D		1 IN 32
BLAKE STOPPERS, SCREW STOPPERS, SHACKLES SECURING TO BUOY	AS SHOWN BELOW	2.51D - 2d		1 IN 16
CABLE CLENCH SHACKLE		2.8D - 2d		1 IN 16
BUOY SHACKLE		3.45D - 2d		1 IN 16
LUGGED ANCHOR SHACKLE		2.9D - 2d		1 IN 16
DIMENSIONS OF TAPERED PINS FOR BLAKE STOPPERS, SCREW STOPPERS, SHACKLES SECURING TO BUOY, CABLE CLENCH, BUOY SHACKLE, LUGGED ANCHOR SHACKLE				
NOMINAL SIZE OF CABLE - D (INCHES)				DIA. AT POINT - d
INCLUDING	3/8	BUT UNDER	11/16	1/8
	11/16		1-3/8	1/4
	1-3/8		1-7/8	3/8
	1-7/8		2-1/2	1/2
	2-1/2		3-3/4	5/8
	3-3/4		4 (INCL)	3/4
DIMENSIONS OF TAPERED PINS FOR TOWING SHACKLES (INCHES)				
SHACKLES FOR USE WITH	d	L		TAPER
3-1/2 AND 5 in. HAWSERS	1/2	4-1/2		1 IN 16
5-1/2 AND 6-1/2 in. HAWSERS	1/2	5-1/8		1 IN 16

Figure 5: Dimensions of Tapered Pins (Ref. A)

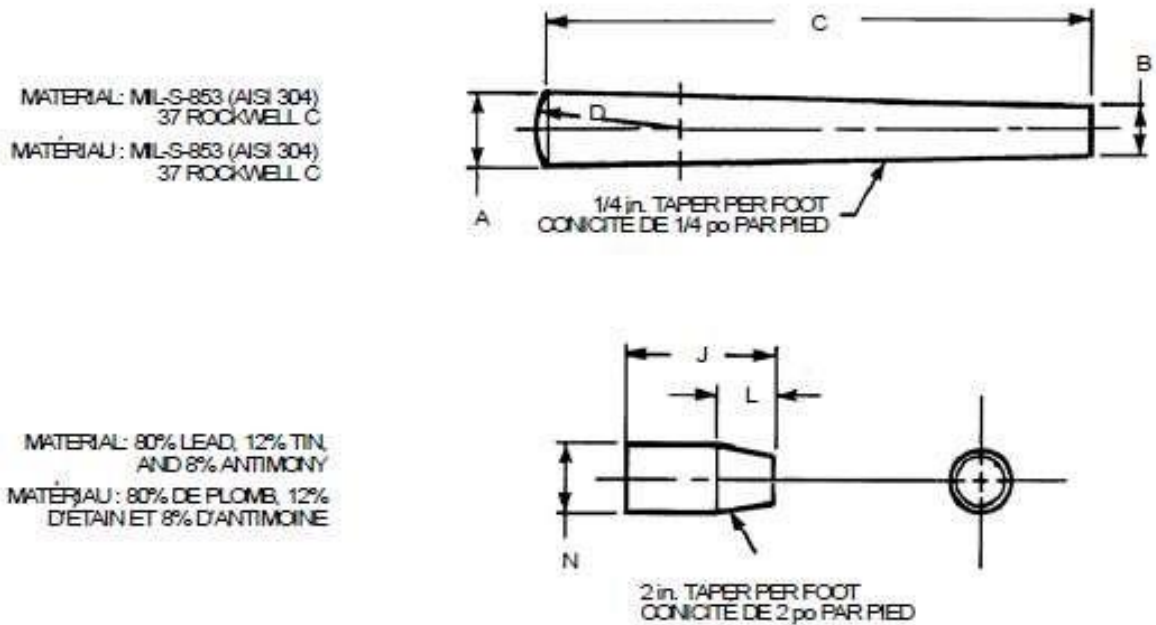

LINK SIZE DIMENSION DU MAILLON	A	B	C	D	J	L	N
3/4	5/16	0.261	2-1/2	7/16	5/8	1/4	9/32
7/8	11/32	0.281	3	1/2	5/8	1/4	5/16
1	13/32	0.338	3-3/8	5/8	13/16	5/16	3/8
1-1/8	15/32	0.389	3-13/16	3/4	1	11/32	7/16
1-1/4	1/2	0.413	4-3/16	15/16	1	3/8	31/64
1-3/8	9/16	0.466	4-21/32	7/8	1	5/16	17/32
1-1/2	5/8	0.517	5-3/16	7/8	1-3/8	1/2	9/16
1-5/8	21/32	0.540	5-9/16	15/16	1-3/8	1/2	5/8
1-3/4	11/16	0.562	6	1-1/8	1-3/8	1/2	11/16
1-7/8	3/4	0.614	6-1/2	1-3/16	1-3/8	9/16	3/4
2	13/16	0.672	6-3/4	1-1/4	1-3/8	9/16	3/4
2-1/8	7/8	0.724	7-1/8	1-5/16	1-3/8	5/8	13/16
2-1/4	15/16	0.781	7-1/2	1-3/8	1-3/8	5/8	29/32
2-3/8	1	0.828	8-1/4	1-1/2	1-5/8	3/4	7/8
2-1/2	1	0.823	8-3/8	1-1/2	2	3/4	31/32
2-5/8	1-1/8	0.875	9	1-5/8	2-1/8	3/4	1-1/16
2-3/4	1-1/8	0.932	9-9/32	1-11/16	2-1/8	3/4	1-3/32
2-7/8	1-11/64	0.970	9-11/16	1-13/16	2-1/8	13/16	1-5/32
3	1-7/32	1.007	10-1/8	1-7/8	2-1/8	7/8	1-3/16
3-1/8	1-17/64	1.046	10-9/16	2	2-3/8	15/16	1-9/32
3-1/4	1-5/16	1.083	11	2	2-1/2	1	1-3/8
3-3/8	1-7/16	1.162	11-3/4	2-1/2	2-3/8	1	1-11/32
3-1/2	1-1/2	1.250	12	2-3/16	2-7/8	1-1/8	1-3/8
3-3/4	1-33/64	1.259	12-21/32	2-1/4	2-7/8	1-3/16	1-7/16

Figure 6: Dimensions of Tapered Pins and Lead Pellets for Baldt Chain Connecting Links (Ref. A) (Dimensions shown are in inches)

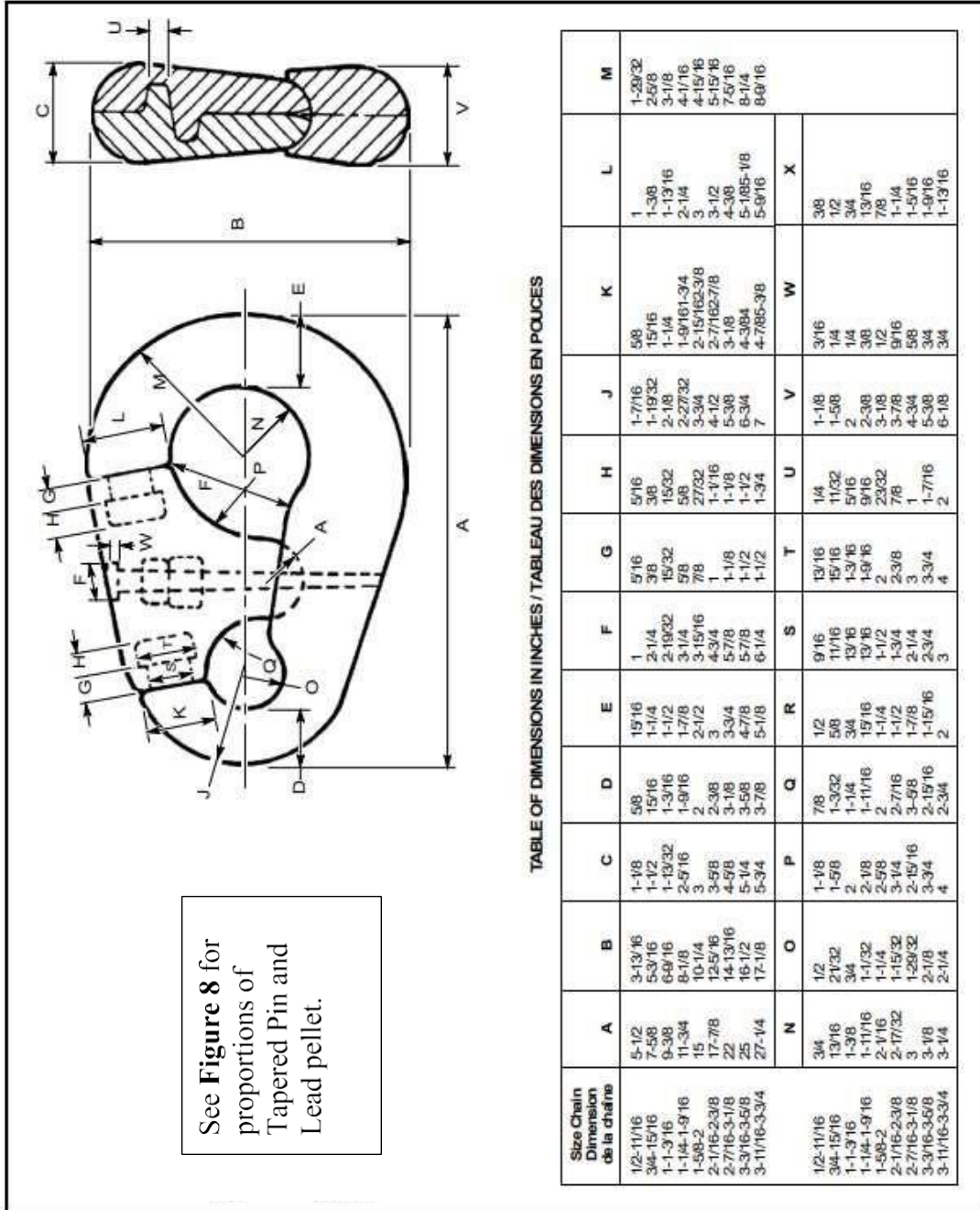

Figure 7: Baldt Anchor Shackle (Ref. A). Will be used on 46mm Chain Cable.

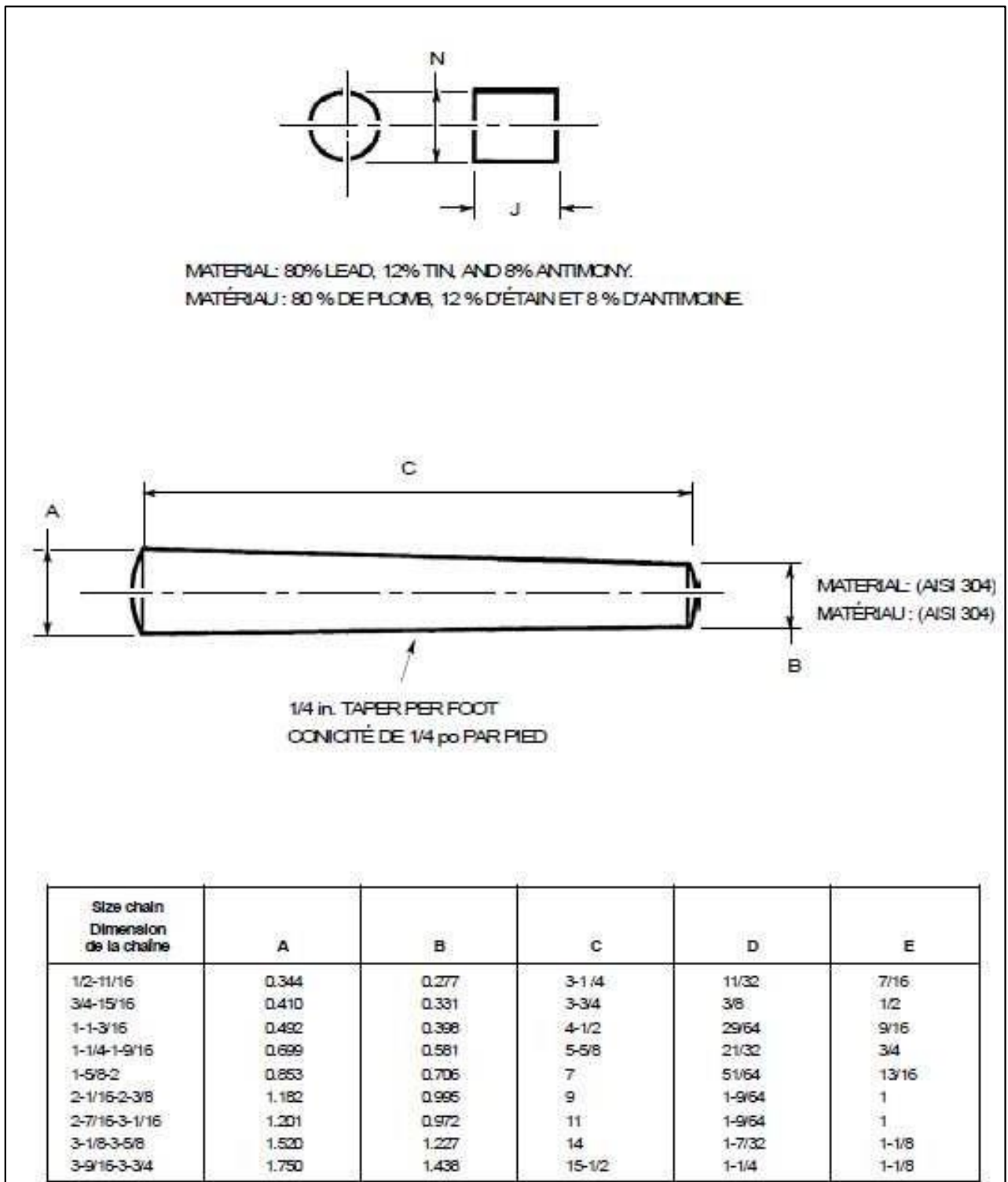

Figure 8: Dimensions of Tapered Pins and Lead Pellets for Baldt Detachable Anchor Connection Link (Ref. A) (Dimensions shown are in inches)

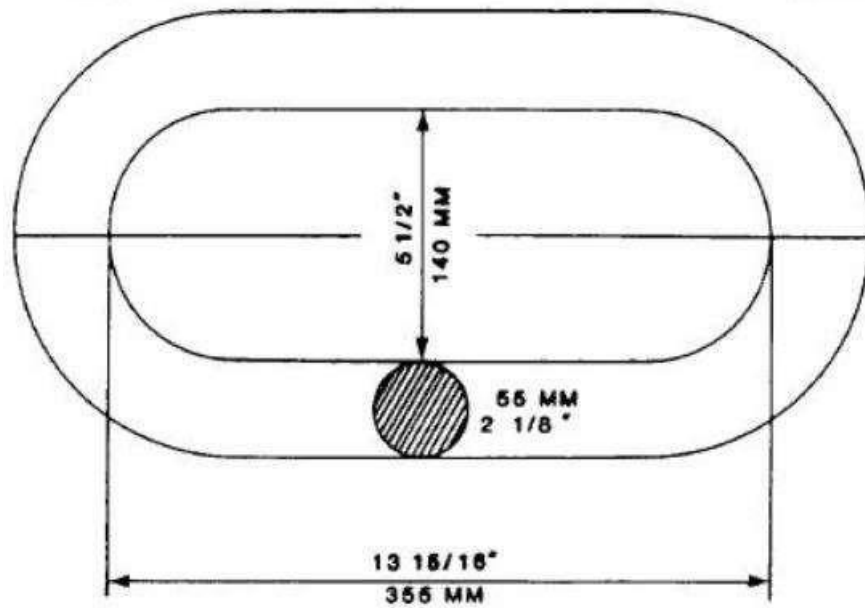

Figure 9: NATO Link

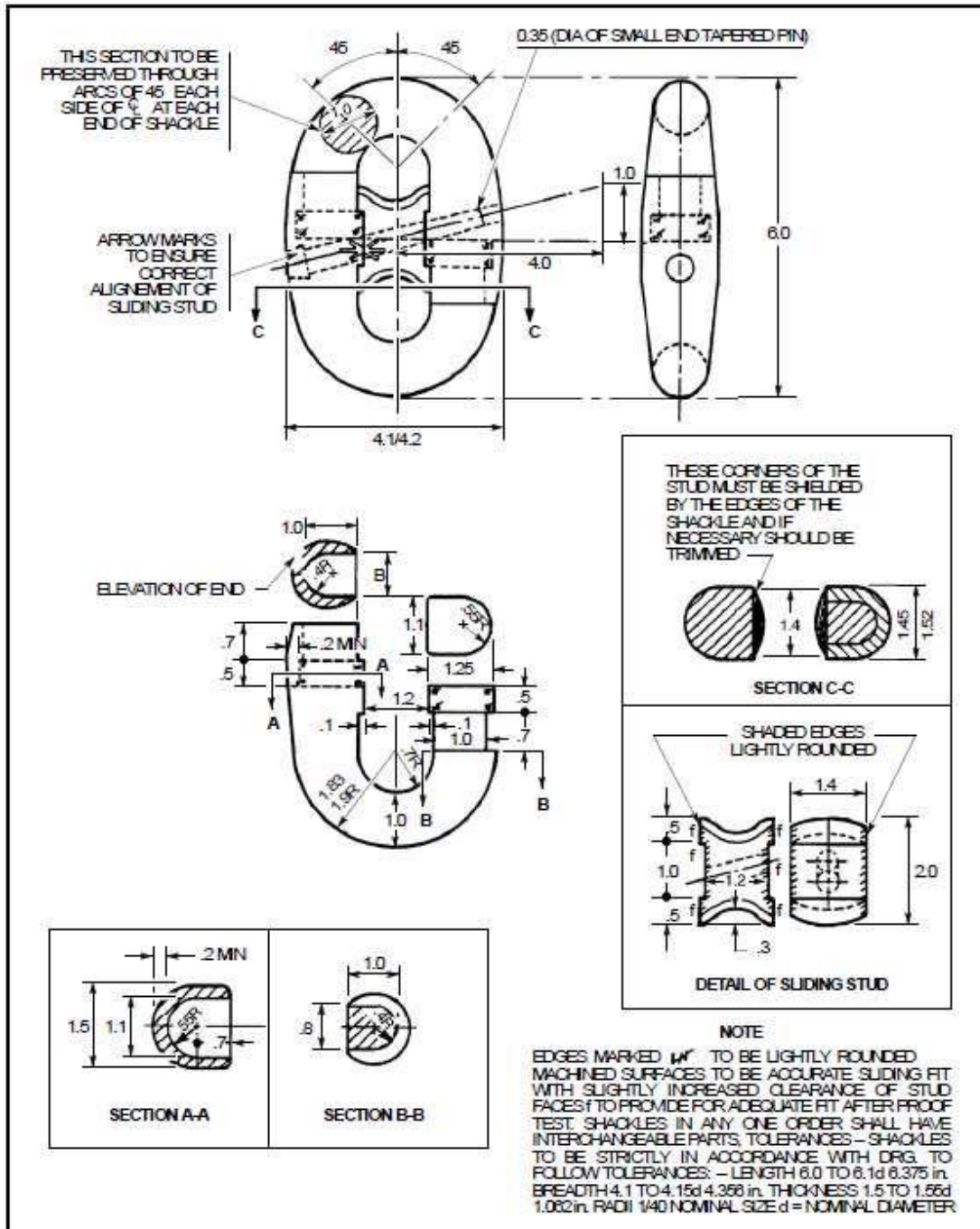

Figure 11: Kenter-Type Lugless Joining Shackle (Ref. A) (Dimensions shown are Nominal Multipliers based on the largest item intended to be used with (i.e. 48 mm towing hawser thimble))

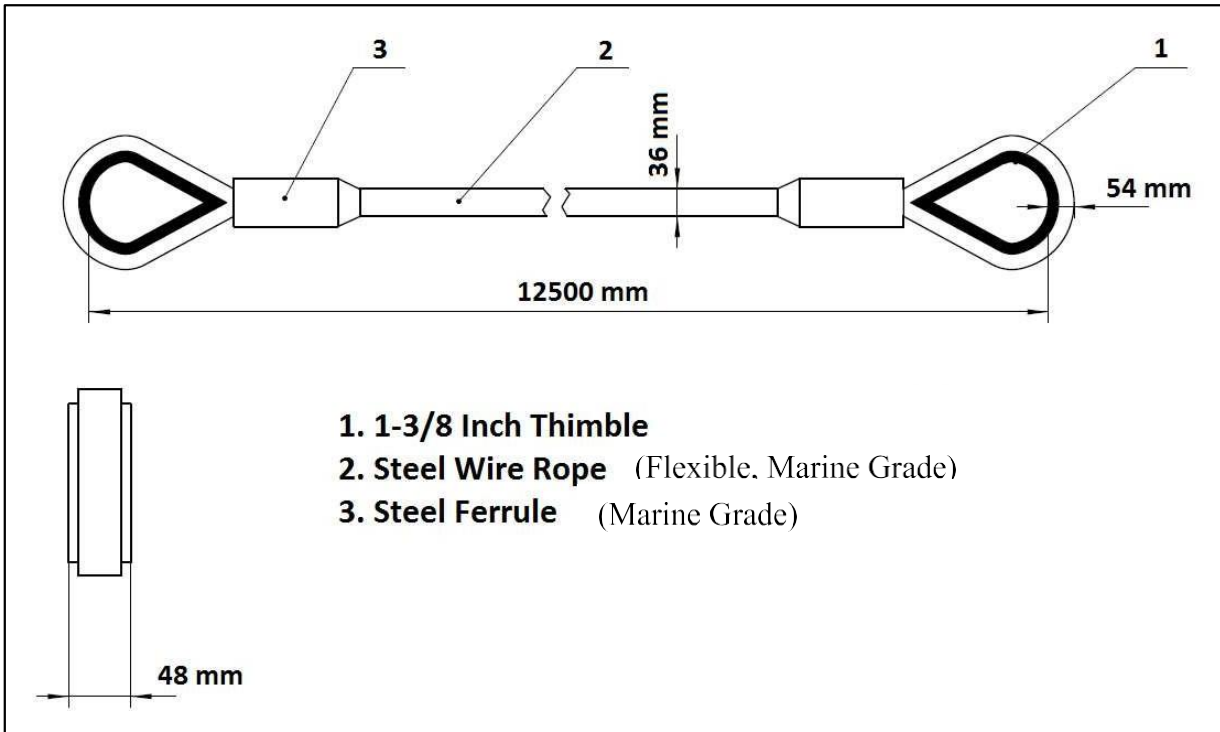

Figure 12: Towing Pendant (Ref. B)

REFERENCES

- A. C-28-010-024-MS-001 Anchors Chain Cables and Associated Articles (2022-06-17)
- B. C-28-898-000-MS-001 HDW Class Mooring and Towing Operation and Maintenance Instructions With Parts Lists

ANNEX "B"

CERTIFICATION REQUIREMENTS

- a. The Towing Gear must be manufactured by approved procedures at works approved by Lloyds Register or A.B.S. Standards. Testing is to be in accordance with Ch 10 of the Lloyd's Register Rules for Manufacture, Testing and Certification of Materials or commensurate IACS member rules and regulations. Loose gear must have a Safe Working Load of not less than 863.75 Kn.
- b. Classification Society Type Approval Certification.
- c. Materiel Forging Certificates.
- d. Load test certificates bearing a professional engineer's seal that conform to the requirements in IACS Unified Requirements A (IACS UR A) for mooring, anchoring, and towing.
- e. List of Items. Item
- f. Item 1, GSIN: 2040, NSN: 20-A0V-2127 SHACKLE, TOWING
- g. Item 2, GSIN: 2040, NSN: 20-A0Z-5572 SENHOUSE SLIP
- h. Item 3, GSIN: 2040, NSN: 20-A0V-2128 SHACKLE, BALDT ANCHOR
- i. Item 4, GSIN: 2040, NSN: 20-A0V-2129 LINK, NATO
- j. Item 5, GSIN: 2040, NSN: 20-A0V-2153 BLAKE SLIP, CENTRE
- k. Item 6, GSIN: 2040, NSN: 20-A0V-2155 SHACKLE KENTER
- l. Item 7, GSIN: 2040, NSN: 20-AI0-2509 TOWING PENDANT

ANNEX “C”

BASIS OF PAYMENT

Bidders must use the table below to indicate their **firm quantity prices** as well as their **optional/additional quantity price**. The table with bidder’s inserted prices must be included in their financial bid.

During the period of the Contract, for Work performed in accordance with the Contract, the Contractor will be paid as specified below.

Item/Description	Firm Cost per Unit\$	Firm Quantity	Firm Quantity Total	Optional Quantity Cost per Unit	Optional Quantity Amount	Optional Quantities Total
Item 1- SHACKLE, TOWING	\$_____	4	\$_____	\$_____	8	\$_____
Item 2- SENHOUSE SLIP	\$_____	2	\$_____	\$_____	4	\$_____
Item 3- SHACKLE, BALDT ANCHOR	\$_____	8	\$_____	\$_____	16	\$_____
Item 4- LINK, NATO	\$_____	4	\$_____	\$_____	8	\$_____
Item 5- BLAKE SLIP, CENTRE	\$_____	2	\$_____	\$_____	4	\$_____
Item 6- SHACKLE KENTER	\$_____	8	\$_____	\$_____	16	\$_____
Item 7- TOWING PENDANT	\$_____	4	\$_____	\$_____	8	\$_____
		Total (Without Tax)	\$_____	\$_____	Total (without Tax)	\$_____

ANNEX D, ELECTRONIC PAYMENT INSTRUMENTS

The Bidder accepts to be paid by any of the following Electronic Payment Instrument(s):

- VISA Acquisition Card;
- MasterCard Acquisition Card;
- Direct Deposit (Domestic and International);
- Electronic Data Interchange (EDI);
- Wire Transfer (International Only);