

-BREAK ALL SHARP EDGES .005-.015
 -TOLERANCE DECIMAL $\pm .005 \pm .0010$
 -MATERIAL TITANIUM T2 GRADE 5

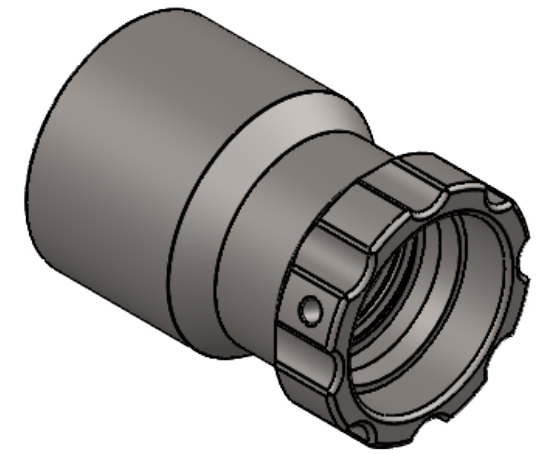

8-32 UNC THRU FIRST BRAKE

1-10 ACME 2G- NOT STANDARD- (1.02 DEEP)
 -MAJOR 0.980-1.00
 -PITCH 0.920-0.935
 -MINOR 0.885-0.895

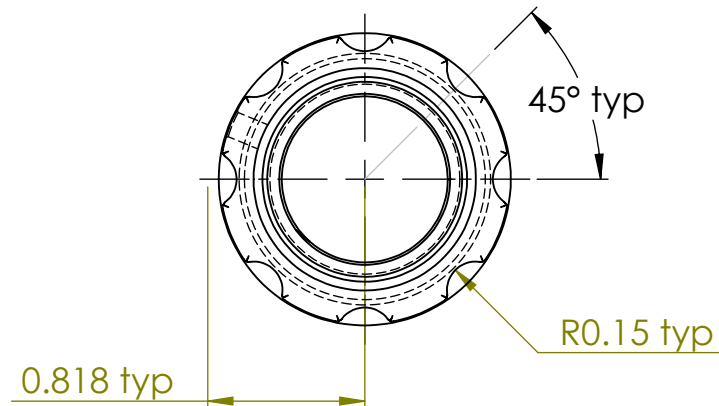
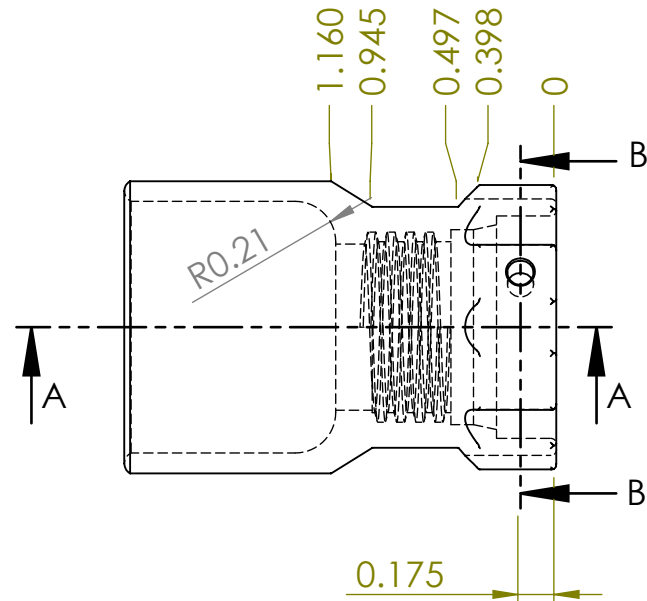
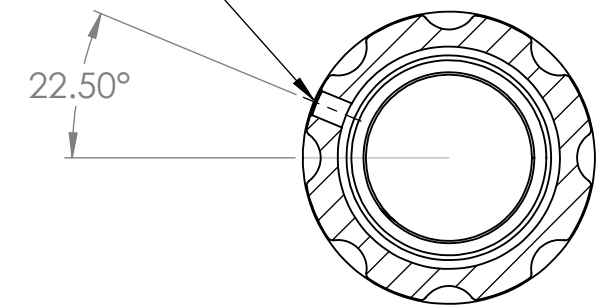

SECTION B-B

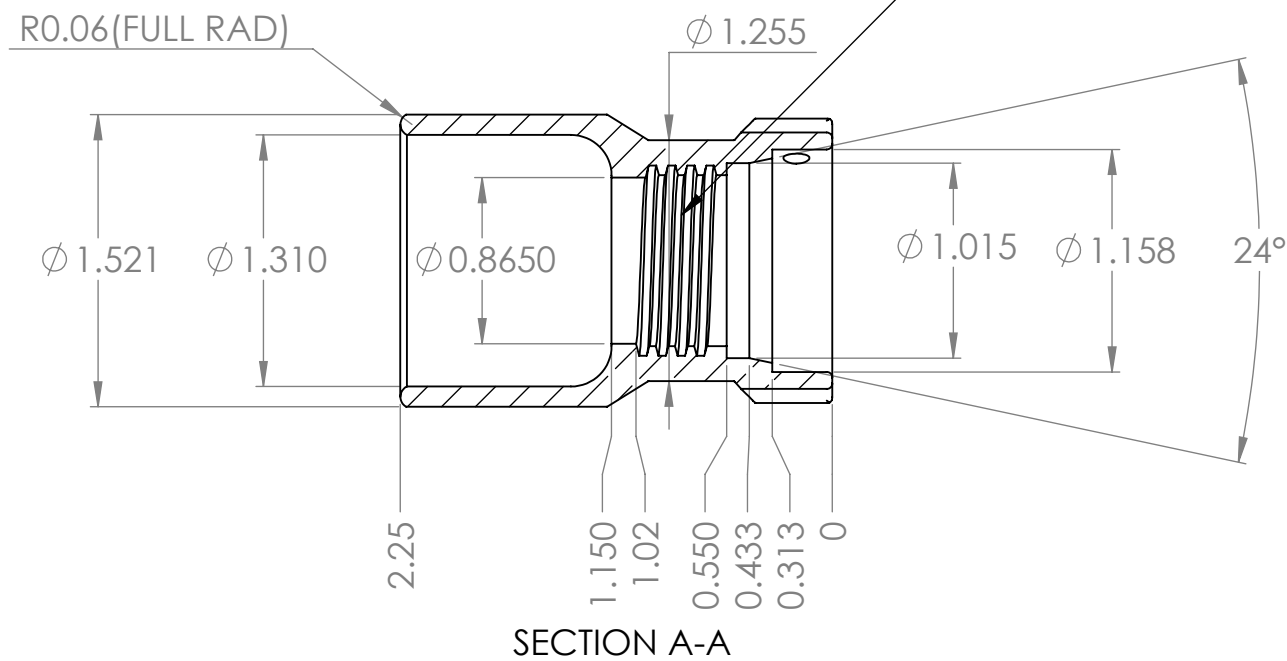

SECTION A-A

UNLESS OTHERWISE SPECIFIED: DIMENSIONS ARE IN MILLIMETERS			FINISH: CLEAN		DEBURR AND BREAK SHARP EDGES		DO NOT SCALE DRAWING		REVISION	
SURFACE FINISH:							RCMP-GRC		TITLE: 90T MUZZLE BRAKE BUSHING 8-32 lock	
TOLERANCES:										
LINEAR:							DWG NO.:		A3	
ANGULAR:							77004521			
DRAWN			NAME		SIGNATURE		DATE		MATERIAL:	
CHK'D									WEIGHT:	
APPV'D									SCALE:1:1	
MFG									SHEET 1 OF 1	
Q.A										