

-BRISER TOUTES ARETES VIVES .005-.015  
 -TOLERANCES DECIMALES +-.005+-.0010  
 -MATERIEL ALU-7075  
 -ANODISATION DURE MIL-A-8625 TYPE III  
 CLASSE 2 NOIR MAT S APPLIQUE APRES ANODISATION

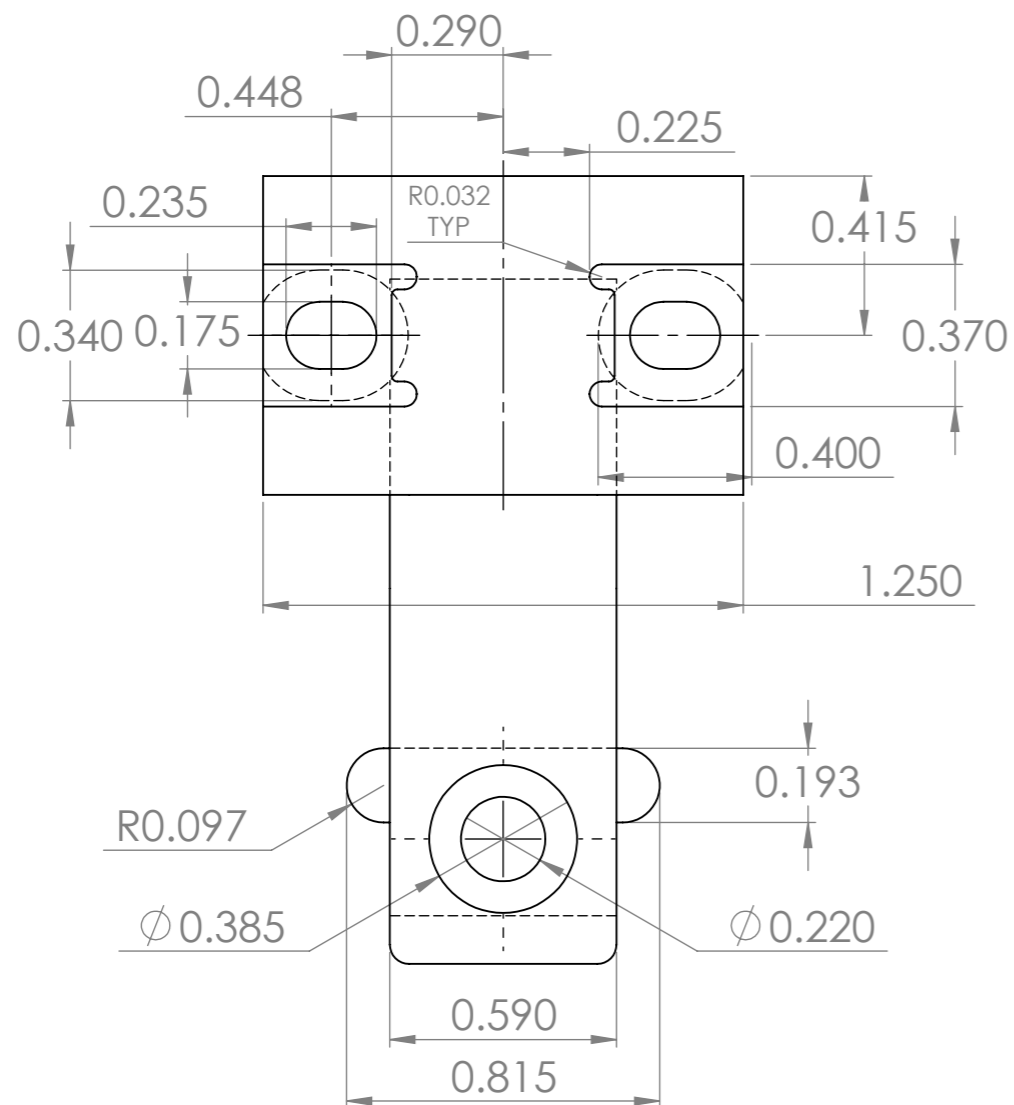
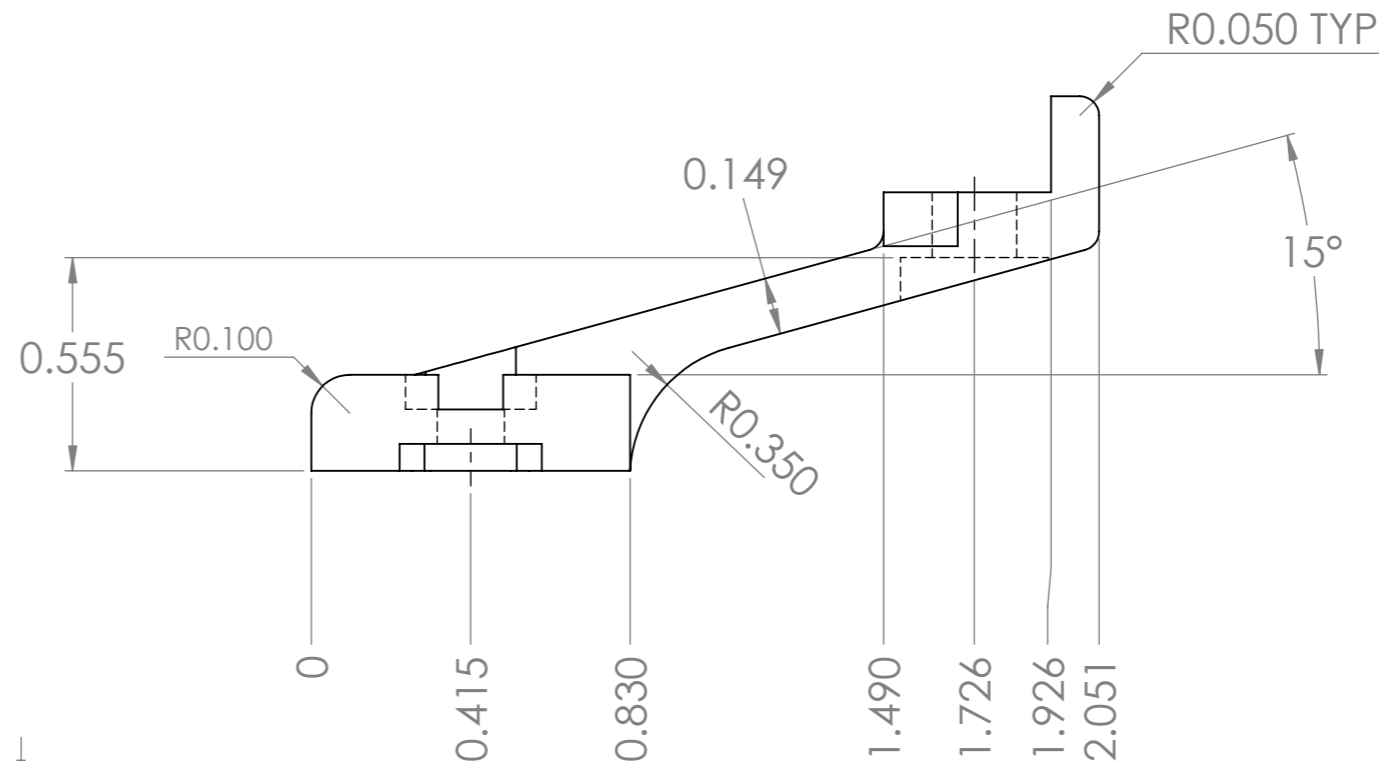
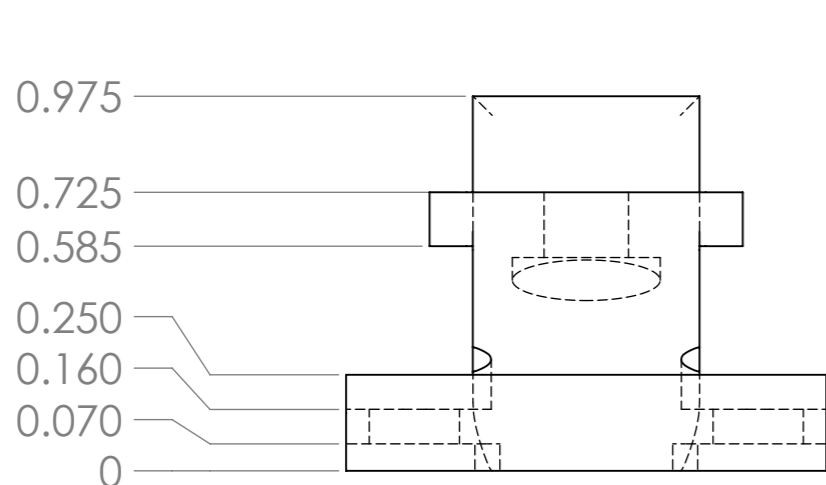
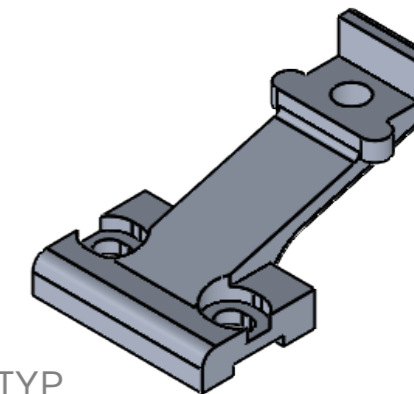

SAUF AVIS CONTRAIRE: LES DIMENSIONS SONT EN MILLIMÈTRES FINI DE SURFACE: TOLÉRANCE: LINÉAIRE: ANGULAIRE:		FINI: <b>PROPRE</b>	ÉBAVURER LES TROUS ET ARRONDIR LES BORDS COUPANTS	NE PAS METTRE LE DESSIN À L'ÉCHELLE	RÉVISION
				<b>GRC-RCMP</b>	
				TITRE: Dispositif de fixation de lumière de 40 mm	
				DESSIN NO. <b>77004532</b>	A3
				ÉCHELLE:2:1	FEUILLE 1 DE 1

NOM	SIGNATURE	DATE
DESSIN		
VÉRIFICATION		
APPROBATION		
FABRICANT		
AQ		
MATÉRIAU: <b>7075-T6</b>		
POIDS:		