



Public Works and
Government Services
Canada

Travaux publics et
Services gouvernementaux
Canada

RETURN BIDS TO:**RETOURNER LES SOUMISSIONS À:**

See Section 1.

Voir Section 1.

STANDARD REQUEST FOR BID**INVITATION À SOUMISSIONNER - STANDARD**

The Bidder offers to provide to Canada the goods, services or both listed in the bid solicitation in accordance with the conditions set out in the bid solicitation and the prices set out in the bid.

This bid solicitation is issued in accordance with the conditions of the Supply Arrangement E60PQ-140003/PQ.

Le soumissionnaire offre de fournir au Canada les biens, services ou les deux énumérés dans la demande de soumissions aux conditions prévues dans la demande de soumissions et aux prix indiqués dans la soumission.

Cette demande de soumissions est émise conformément aux conditions de l'arrangement en matière d'approvisionnement E60PQ-140003/PQ.

Solicitation No. - N° de la demande	Amendment No. - N° de modification
Supplier SA No. - N° de l'AMA de fournisseur : E60PQ-140003/___	

Solicitation closes – La demande prend fin :	File No. - N° de dossier
at – à See Section 1 Voir Section 1	
on – le See Section 1 Voir Section 1	

No of Page/

N° de page 24

Date of Solicitation – Date de la demande

October 16, 2023

Address inquiries to – Adresser toute demande de renseignement à :

See Section 2, Article 4.1.

Voir Section 2, Article 4.1

Destination

See Section 2, Annex A.

Voir Section 2, Annexe A.

Instructions:

Municipal taxes are not applicable.

Unless otherwise specified in the bid solicitation, all prices quoted must be net prices in Canadian funds including Canadian customs duties, excise taxes, must be FOB, including all delivery charges to destination(s) as indicated. The amount for Applicable Taxes is to be shown as a separate item.

Instructions:

Les taxes municipales ne s'appliquent pas.

Sauf indication contraire dans la demande de soumissions, tous les prix indiqués doivent être des prix nets, en dollars canadiens, comprenant les droits de douane canadiens, la taxe d'accise et doivent être FAB, y compris tous frais de livraison à la (aux) destination(s) indiqué(s). Le montant des taxes applicables doit apparaître séparément.

Supplier Name and Address – Nom et adresse du fournisseur

Telephone No. - N° de téléphone

Facsimile No. - N° de télécopieur

Name and title of person authorized to sign on behalf of supplier (type or print)

Nom et titre de la personne autorisée à signer au nom du fournisseur (caractère d'impression)

Signature : _____ Date : _____

TABLE OF CONTENTS

Section 1 – Invitation and Instructions to Bidders

Section 2 – Resulting Contract including a list of required goods and services

SECTION 1 – INVITATION AND INSTRUCTIONS TO BIDDERS

Step 1. For Tier 2 and Tier 3 only (If Tier 1, skip this step and proceed with step 2)

Is this a Manufacturer Product Specific Procurement? No.

Step 2. Competitive or Non-Competitive

A bid must comply with the requirements of the bid solicitation and meet all mandatory technical evaluation criteria to be declared responsive. The responsive bid with the lowest evaluated price will be recommended for award of a contract.

Canada will assess bids and award one contract for the combined categories included in this solicitation.

For Competitive Requirements when only one bid is received:

The Bidder must provide the following information AFTER bid closing, if requested to do so by Canada:

- One or more of the following price justifications:
 1. a current published price list indicating the percentage discount available to Canada; or
 2. a copy of paid invoices for the like quality and quantity of the goods, services or both sold to other customers; or
 3. a price breakdown showing the cost of direct labour, direct materials, purchased items, engineering and plant overheads, general and administrative overhead, transportation, etc., and profit; or
 4. any other supporting documentation as requested by Canada.

For Non-Competitive Requirements:

The Bidder must provide the following information WITH the bid:

- One or more of the following price justifications:
 1. a current published price list indicating the percentage discount available to Canada; or
 2. a copy of paid invoices for the like quality and quantity of the goods, services or both sold to other customers; or
 3. a price breakdown showing the cost of direct labour, direct materials, purchased items, engineering and plant overheads, general and administrative overhead, transportation, etc., and profit; or
 4. any other supporting documentation as requested by Canada.

Step 3. General or PSIB

Terms of the RFB:

This RFB is issued pursuant to the Supplier's Furniture for Workspaces Supply Arrangement (SA) that forms part of the series of SAs issued by PWGSC with the number E60PQ-140003/PQ. The terms and conditions in the Supplier's SA apply to and form part of this RFB. Bidders who submit a bid agree to be bound by those terms and conditions as well as the terms and conditions in this RFB.

The WTCM is the Workspaces Terms and Conditions Manual that contains all terms and conditions in full text that form part of individual RFBs under this SA.

The Bidder must provide the following information WITH the bid:

- The information requested by Canada in Annex A herein.

The Bidder must also provide the information at article 4 below at the time indicated in article 3.

Security Requirement:

1. Conditions:
the Bidder and the Bidder's proposed individuals must respect the security requirement as indicated in Annex B and at section 2.1.
2. For additional information on security requirements, bidders should refer to the Canadian Industrial Security Directorate (CISD), Industrial Program of Public Works and Government Services Canada (<http://ssi-iss.tpsgc-pwgsc.gc.ca/index-eng.html>) website.
3. The conditions in article 1 above must be met by the Bidder:
Before the award of a contract. Bidders are reminded to obtain the required security clearance promptly. Any delay in the award of a contract to allow the successful bidder to obtain the required clearance will be at the entire discretion of the Contracting Authority.
4. Bidders are to supply the following information, as a minimum, to demonstrate compliance with the Security Requirement.
 - a. The Bidder's valid VOS clearance number issued by CISD;
 - b. The name of all individuals who will require access to classified or protected information, assets or sensitive work sites. It is desirable to also include their date of birth, their middle name, and their security clearance number issued by CISD.

Bid Evaluation

An evaluation team composed of representatives of Canada will evaluate the bids.

RFB Issued to:	
Supplier Name and Address: (City, Province)	
Contact:	
- Name:	
- Telephone Number:	
- E-mail:	
RFB Issued by:	
Identified User's (IU) Department/Agency/Crown Corporation: Contact for this RFB:	See Section 2, article 4.1 below.
RFB Closing - Submit Bid: Bids must be submitted on the date and at the time indicated below.	
By no later than date and time:	October 27, 2023, at 2 pm EDT
To e-mail address:	solicitation-demandedesoumission@cnscccsn.gc.ca
RFB Enquiries:	
Unless a different period is listed in the adjacent column, Bidders may submit enquires about the RFB to the Contracting Authority two business days prior to the RFB closing date. Enquiries received after the timeline indicated may not be answered.	2 business days

SECTION 2 - RESULTING CONTRACT CLAUSES

1.	Terms and Conditions of the Contract	
	The terms and conditions of Parts 6B and 6C of the Supplier's SA within the series E60PQ-140003/PQ apply to and form part of this Contract.	
2.	Security Requirement (the checked article applies)	
2.1	The applicable security requirement(s) is (are) set out in the Security Requirement Check List attached as Annex B of this contract. The Contractor must fulfill the security requirements by meeting the terms below.	
a.	<input checked="" type="checkbox"/>	Contractor may be escorted; possession of security clearance not required. Contractor personnel MAY NOT ENTER NOR PERFORM WORK ON sites where PROTECTED or CLASSIFIED information or assets are kept, without an escort provided by the department or agency for which the work is being performed.
b.	<input type="checkbox"/>	Possession of security clearance(s) is required. The Contractor must meet the security clearance requirements contained in the clausing in Annex B herein.
c.	<input type="checkbox"/>	There is no security requirement associated with this contract.
3.	Requirement	
3.1	The Contractor must perform the Work listed in Annex A herein.	
4.	Authorities	
4.1	Contracting Authority (IU)	
	Name:	Janie Latouche
	Title:	Contracting specialist
	Department/Agency/Crown Corporation:	Canadian Nuclear Safety Commission (CNSC)
	Address:	280 Slater st. Ottawa, ON
	Telephone No.:	
	E-mail address:	solicitation-demandedesoumission@cnsccsn.gc.ca
4.2	Project Authority <i>[To be completed at contract award]</i> <i>The Project Authority (PA) is the representative of the department or agency for whom the Work is being carried out under the Contract including the provision to approve the authority to proceed for delivery and installation and is responsible for all matters concerning the technical content of the Work under the Contract.</i> <i>In addition, the PA is also responsible for ensuring that the Supplier's employees and subcontractors requiring access to the site adhere to the allocated time for the Supplier to access the site to deliver and install the furniture in accordance with the master schedule held by the General Contractor (a representative of Canada or a service provider(s) under contract with the Government of Canada).</i>	
	Name:	<i>[To be completed at contract award]</i>
	Title:	<i>[To be completed at contract award]</i>
	Department/Agency/Crown Corporation:	<i>[To be completed at contract award]</i>
	Address:	<i>[To be completed at contract award]</i>
	Telephone No.:	<i>[To be completed at contract award]</i>
	E-mail address:	<i>[To be completed at contract award]</i>
4.3	Contractor's Representative	
	As set out in Annex A, Table 9 below.	
5.	Method of Payment	
	The checked box applies. If the Contractor's SA indicates acceptance for payment by credit card, that method may be used in conjunction with the following.	
	<input checked="" type="checkbox"/>	Single Payment
	<input type="checkbox"/>	Multiple Payment
6.	Invoicing	
	Further to the Invoicing terms of the WTCM document, the Contractor will deliver the original and one copy of the invoice to the following address for certification and payment:	

	Name of the organization and contact: <i>[To be completed at contract award]</i>
	Address: <i>[To be completed at contract award]</i>
7.	SACC Manual Clauses

Supplemental General Conditions:

SACC Clause D0018C (2007-11-30) Delivery and Unloading:

1. Delivery trucks must be equipped with an unloading device which will permit unloading at sites with no hydraulic, stationary or other type of unloading facility.
2. When making deliveries, sufficient personnel must be provided to permit unloading of any type of vehicle without the assistance of federal government personnel.
3. At some sites, the delivery truck must be unloaded while parked at the curb. When material is placed on the sidewalk, it must be placed in proximity to the designated entrance so as to be readily accessible to transport by mechanical handling equipment utilized by site personnel.

**ANNEX A
REQUIREMENT and BASIS OF PAYMENT**

1. Category Selection

Combined Categories Rule:

For reasons of compatibility, the following categories will be combined for evaluation and contract award purposes:

The rule only applies to the categories below that are checked. The unchecked categories will be evaluated separately and may be awarded to multiple suppliers;

Category 1

Category 2

Category 5

*** Exception: when using the Cat 1, 2, 5 combined categories rule, IU's may calculate the percentage of NSA product allowed (as defined in their solicitation document) against the total quantity of the combined categories.**

Design Upgrade Rule:

The IU may exercise an option to upgrade products up to 20% of each Category product total before Applicable Taxes after contract award.

The Design Upgrade amount is used at the discretion of the Project Authority (PA) **prior to the manufacturing/ordering of the products**, the PA will provide the Contractor with a written notice of Canada's Design Upgrade choices for each of the product(s) to be upgraded. The Contractor will provide the pricing of the upgraded product(s) to a maximum of 20% of each Category Contract Price of Table 8. The Contracting Authority will issue an amendment to the contract with the Design Upgrades and pricing.

The Supplier certifies that all the Design Upgraded products offered will conform to all specifications and meet the testing requirements detailed in the Specifications of the Supply Arrangement.

Design Upgrade: is the process of replacing a product with a more innovative or enhanced version of the same product.

NSA:

NSA products can be incorporated in the RFB and must not exceed 30% of the firm quantity by category. NSA items must be added to the category that is most closely related and must be generic.

The requirement includes the following category (ies) of work

a. Category 1 – Interconnecting Panels and Freestanding Systems

Category 1a – Interconnecting Panels (Refer to Annex C)

Category 1b – Supporting components and freestanding furniture

RULE: Metal Storage

Identified Users may procure metal storage products forming part of Category 1 when the metal storage products will be part of a requirement for a workstation(s)/work point(s). If this rule does not apply, Category 3 must be used for the metal storage products forming part of this category.

b. Category 2 – Freestanding Height Adjustable Desk / Table Products

c. Category 3 – Metal Filing and Storage Cabinets

Identifying the maximum height of the Personal Storage Towers, Wardrobes and Storage Cabinets is acceptable as per 6B. 4.1 of the SA (table 1 Additional product details)

d. Category 4 – Wood Veneer – Freestanding Products

e. Category 5 – Ancillary and Lighting Products

f. Category 6 - Support Space – Collaborative Furniture

RULE: Category 6 can be further subdivided by space or like product in order to increase or allow competition. Space is defined as a location available for a particular purpose such as a meeting room space or a collaborative space. Like products are defined as products with similar design and construction. If NSA products form part of the requirement, the IU must validate the 30% NSA prior to subdividing the category. NSA products can be added to any subdivide or in its own subdivide.

The IU must identify how Category 6 will be subdivided in the Product Table for Category 6.

g. NSA Product(s) – Category(ies): N/A

2. Product and Pricing Tables

Site Inspection Date: To be coordinated with Project Authority after contract award. (Refer to Annex A article 4 of the SA for Site Inspection and Documentation instructions.)

INSTRUCTIONS TO BIDDERS: Bidders are to complete Sections B of the tables identified by the IU in this article as well as Tables 8 and 9. **Bidders must provide a complete product offering for each category, or CAT 6 sub-divide they wish to submit a bid in order to be compliant.**

****Refer to article 6A.7 for instructions on how to submit products that are not approved in product listing.****

In a resulting contract, the term “Bid” means the Supplier’s commitment, the term “Bidder” means “Contractor”.

Product Categories: 1, 2 & 5

Table 1 – Product Table

Section A - IU REQUIREMENT					Section B – SUPPLIER'S BID		
#	GoCUID	Description of Product (Additional product details may be inserted, if required as per 6B. 4.1 of the SA)	QTY	** Provide additional Information Yes/No	Supplier Part Number	Firm Unit Price \$	Extended Total [Qty x Price] \$
Category 1A							
1	Refer to Typical Package and Floor Plans						\$
Category 1B							
2	1bFFHREN24L60WNOLNY	Tag: 1B.1 Fixed Height Work Surface 1524mm x 609mm (60" x 24")	12	No		\$	\$
3	1bFFHREL24L60WNOLNY	Tag: 1B.2 Fixed Height Work Surface 1524mm x 609mm (60" x 24")	1	No		\$	\$
4	1bSPBMCAA1524XXYKXX	Tag: 1B.3 Mobile Box/File Pedestal	17	No		\$	\$
Category 2							
5	2WSSREXXL24L48BELXX	Tag: 2A Individual Height Adjustable Work Surface 1219mm x 609mm (48" X 24")	13	No		\$	\$
6	2WSSREXXL30L60BELXX	Tag: 2B Individual Height Adjustable Work Surface 1524mm x 762mm (60" X 30")	2	No		\$	\$
7	2WSSREXXL30L72BELXX	Tag: 2C Individual Height Adjustable Work Surface 1829mm x 762mm (72" X 30")	2	No		\$	\$
Category 5							
8	5PMOWKSMTACPWRXXXXX	Tag: 5A Power Module Must Have 4 Simplex and 2 USB Ports		Yes		\$	\$
**Provide additional information: Canada is requesting bidders: to provide drawings and/or pictures including descriptive literature for these products with your bid submission.							

Table 2 - Delivery

Section A - IU REQUIREMENT				Section B – SUPPLIER'S BID	
Product Item # from Table 1	Location	Desired Date** (YYYY-MM-DD)	Desired Time: Normal Business Hours Or Outside Normal Business Hours *	Supplier will supply and deliver as per below**	Firm Lot Price \$
1	Category 1A Panels	3484 Limebank Rd. Gloucester, ON, K1V 1E1	Week of December 18, 2023. Specific date to be provided by Project Authority	Normal	_____ : weeks <i>Standard Lead time is between 6-10 weeks for furniture delivery and installation.</i>
2	<u>Tag 1B.1</u> Qty: 12				
3	<u>Tag 1B.2</u> Qty: 1				
4	<u>Tag 1B.3</u> Qty: 17				
5	<u>Tag 2A</u> Qty: 13				
6	<u>Tag 2B</u> Qty: 2				
7	<u>Tag 2C</u> Qty: 2				
8	<u>Tag 5A</u> Qty: 17				
*Normal Business Hours 8:00 – 17:00, as per SA, Annex A, article 5				Delivery Total:	\$
**The Project Authority (PA) will provide the supplier the authority to proceed prior to the finalized delivery date taking into consideration the delivery time provided by the supplier. Canada will not be responsible if the supplier chooses to proceed without the PA authorization.					

Table 3 – Installation

Section A - IU REQUIREMENT				Section B – SUPPLIER'S BID	
Product Item # from Table 1	Location	Desired Date** (YYYY-MM-DD)	Desired Time: Normal Business Hours Or Outside Normal Business Hours *	Supplier will install as per below**	Firm Lot Price \$
1	Category 1A Panels	3484 Limebank Rd. Gloucester, ON, K1V 1E1	Normal	_____ : weeks from date of supply and delivery <i>Standard Lead time is between 6-10 weeks for furniture delivery and installation.</i>	\$
2	<u>Tag 1B.1</u> Qty: 12				
3	<u>Tag 1B.2</u> Qty: 1				
4	<u>Tag 1B.3</u> Qty: 17				
5	<u>Tag 2A</u> Qty: 13				
6	<u>Tag 2B</u> Qty: 2				
7	<u>Tag 2C</u> Qty: 2				
8	<u>Tag 5A</u> Qty: 17				
*Normal Business Hours 8:00 – 17:00, as per SA, Annex A, article 5				Installation Total:	\$
**The Project Authority (PA) will provide the supplier the authority to proceed prior to the finalized installation date taking into consideration the installation time provided by the supplier. Canada will not be responsible if the supplier chooses to proceed without the PA authorization.					

Table 4 – Optional Product Not Applicable

Table 5 – Optional Delivery Not Applicable

Table 6 – Optional Installation Not Applicable

Table 7 – Standard Finishes and Canada’s Facilities to Accommodate the Delivery and Certifications

1.	Standard Finishes	
1.1	<p>IU is to consult the Supplier’s Website identified in Part 6A of the SA to view the available finishes.</p> <p>Within ten business days of the contract award, the Project Authority will provide the Contractor with a written notice of Canada’s finish choices for each of the product(s) in Annex A.</p> <p>The Contractor will deliver the products corresponding to Canada’s choice of specific finishes(s). No additional charge will be applied to Canada.</p>	
2.	Canada’s Facilities to Accommodate the Delivery	
	<p><i>The Supplier’s employees and subcontractors requiring access to the site must adhere to the health and safety plans established for the site, in addition to any laws in effect in the jurisdiction where the work is being performed.</i></p> <p><i>During the period of the contract, a representative of Canada or a service provider(s) under contract with the Government of Canada may request the list of employees and subcontractors requiring access to the site to perform the work and their security statuses. Information must be provided in the timeframe prescribed in order to ensure that the supply, delivery and installation of the furniture aligns with the master schedule.</i></p>	
2.1	Loading Dock/Location	
A	Location	3484 Limebank Road, Ottawa, ON K1V 1E1
B	Dock	Ground Floor
C	Lift	Truck will need a lift gate
D	Door	Overhead door is approx. 8’h x 10’w
E	Freight Elevator	No elevator. Work is done on the ground floor.
F	Other (specify, if any)	
3.	Continuance of Certifications	
	<p>The Bidder certifies that by submitting a bid in response to the RFB, the Bidder, and any of the Bidder’s members if the Bidder is a Joint Venture, continues to comply with all of the following certifications listed in Parts 6A and 6B of the Bidder’s SA for Work Spaces.</p> <p>Canada may request copies of environmental certification(s) prior to contract award within a time period specified by the Identified User.</p>	
3.1	Integrity Provisions	
3.2	Federal Contractor’s Program for Employment Equity	
3.4	Product Conformance	
3.5	Price Certification (In accordance with the SA, Part 6B)	

Table 8 - Bid Evaluation and Contract Total*(Canada may complete if not completed by the Bidder)*

1	Firm Product Total (Table 1)	\$
2	Firm Delivery Total (Table 2)	\$
3	Firm Installation Total (Table 3)	\$
4	Optional Product Total (Table 4) <i>(Applicable if Option is exercised)</i>	\$N/A
5	Optional Delivery Total (Table 5) <i>(Applicable if Option is exercised)</i>	\$ N/A
6	Optional Installation Total (Table 6) <i>(Applicable if Option is exercised)</i>	\$ N/A
7	Hardware Total as per article 1.5 of Annex A-1 of SA <i>(if Applicable)</i>	\$
8	Total Evaluated (Bid) Price* (1 + 2 + 3 + 4 + 5 + 6 + 7) <i>[to be removed at contract award]</i>	\$
9	Contract Price(1 + 2 + 3 + 7): <i>[applicable at contract award only]</i>	\$
10	Applicable Tax(es): <i>[applicable at contract award only]</i>	\$
11	Total Estimated Cost (9 + 10): <i>[applicable at contract award only]</i>	\$

* Applicable taxes extra.

Table 9 – Bidder’s Authorized Representative

1.	Bidder’s Authorized Representative for the Bid and the Contract		
	Name:	Telephone:	
		E-Mail:	
		PBN:	
		Ariba #:	

**ANNEX B
SECURITY REQUIREMENTS**

The security requirements set out in the attached Security Requirements Check List (SRCL) and in the terms below apply to and form part of the Contract.

1. The Contractor and/or its personnel **MUST NOT** have access to PROTECTED and/or CLASSIFIED information or assets.
2. The Contractor and/or its personnel **MUST NOT** have unescorted access to Canadian Nuclear Safety Commission facilities and/or restricted access areas.
3. The Contractor must comply with the provisions of the Security Requirement Check List attached to this Contract as Annex B, below:



Government of Canada / Gouvernement du Canada

Contract Number / Numéro du contrat 5000076955
Security Classification / Classification de sécurité Unclassified

**SECURITY REQUIREMENTS CHECK LIST (SRCL)
LISTE DE VÉRIFICATION DES EXIGENCES RELATIVES À LA SÉCURITÉ (LVERS)**

PART A - CONTRACT INFORMATION / PARTIE A - INFORMATION CONTRACTUELLE			
1. Originating Government Department or Organization / Ministère ou organisme gouvernemental d'origine		2. Branch or Directorate / Direction générale ou Direction	
CNSC		CFAD	
3. a) Subcontract Number / Numéro du contrat de sous-traitance		3. b) Name and Address of Subcontractor / Nom et adresse du sous-traitant	
4. Brief Description of Work / Brève description du travail Supply and install system furniture			
5. a) Will the supplier require access to Controlled Goods? Le fournisseur aura-t-il accès à des marchandises contrôlées?		<input checked="" type="checkbox"/> No / Non	<input type="checkbox"/> Yes / Oui
5. b) Will the supplier require access to unclassified military technical data subject to the provisions of the Technical Data Control Regulations? Le fournisseur aura-t-il accès à des données techniques militaires non classifiées qui sont assujetties aux dispositions du Règlement sur le contrôle des données techniques?		<input checked="" type="checkbox"/> No / Non	<input type="checkbox"/> Yes / Oui
6. Indicate the type of access required / Indiquer le type d'accès requis			
6. a) Will the supplier and its employees require access to PROTECTED and/or CLASSIFIED information or assets? Le fournisseur ainsi que les employés auront-ils accès à des renseignements ou à des biens PROTÉGÉS et/ou CLASSIFIÉS? (Specify the level of access using the chart in Question 7. c) (Préciser le niveau d'accès en utilisant le tableau qui se trouve à la question 7. c)		<input checked="" type="checkbox"/> No / Non	<input type="checkbox"/> Yes / Oui
6. b) Will the supplier and its employees (e.g. cleaners, maintenance personnel) require access to restricted access areas? No access to PROTECTED and/or CLASSIFIED information or assets is permitted. Le fournisseur et ses employés (p. ex. nettoyeurs, personnel d'entretien) auront-ils accès à des zones d'accès restreintes? L'accès à des renseignements ou à des biens PROTÉGÉS et/ou CLASSIFIÉS n'est pas autorisé.		<input type="checkbox"/> No / Non	<input checked="" type="checkbox"/> Yes / Oui
6. c) Is this a commercial courier or delivery requirement with no overnight storage? S'agit-il d'un contrat de messagerie ou de livraison commerciale sans entreposage de nuit?		<input checked="" type="checkbox"/> No / Non	<input type="checkbox"/> Yes / Oui
7. a) Indicate the type of information that the supplier will be required to access / Indiquer le type d'information auquel le fournisseur devra avoir accès			
Canada <input type="checkbox"/>	NATO / OTAN <input type="checkbox"/>	Foreign / Étranger <input type="checkbox"/>	
7. b) Release restrictions / Restrictions relatives à la diffusion			
No release restrictions Aucune restriction relative à la diffusion <input type="checkbox"/>	All NATO countries Tous les pays de l'OTAN <input type="checkbox"/>	No release restrictions Aucune restriction relative à la diffusion <input type="checkbox"/>	
Not releasable À ne pas diffuser <input type="checkbox"/>			
Restricted to: / Limité à: <input type="checkbox"/>	Restricted to: / Limité à: <input type="checkbox"/>	Restricted to: / Limité à: <input type="checkbox"/>	
Specify country(ies): / Préciser le(s) pays:	Specify country(ies): / Préciser le(s) pays:	Specify country(ies): / Préciser le(s) pays:	
7. c) Level of information / Niveau d'information			
PROTECTED A PROTÉGÉ A <input type="checkbox"/>	NATO UNCLASSIFIED NATO NON CLASSIFIÉ <input type="checkbox"/>	PROTECTED A PROTÉGÉ A <input type="checkbox"/>	
PROTECTED B PROTÉGÉ B <input type="checkbox"/>	NATO RESTRICTED NATO DIFFUSION RESTREINTE <input type="checkbox"/>	PROTECTED B PROTÉGÉ B <input type="checkbox"/>	
PROTECTED C PROTÉGÉ C <input type="checkbox"/>	NATO CONFIDENTIAL NATO CONFIDENTIEL <input type="checkbox"/>	PROTECTED C PROTÉGÉ C <input type="checkbox"/>	
CONFIDENTIAL CONFIDENTIEL <input type="checkbox"/>	NATO SECRET NATO SECRET <input type="checkbox"/>	CONFIDENTIAL CONFIDENTIEL <input type="checkbox"/>	
SECRET SECRET <input type="checkbox"/>	COSMIC TOP SECRET COSMIC TRÈS SECRET <input type="checkbox"/>	SECRET SECRET <input type="checkbox"/>	
TOP SECRET TRÈS SECRET <input type="checkbox"/>		TOP SECRET TRÈS SECRET <input type="checkbox"/>	
TOP SECRET (SIGINT) TRÈS SECRET (SIGINT) <input type="checkbox"/>		TOP SECRET (SIGINT) TRÈS SECRET (SIGINT) <input type="checkbox"/>	



Contract Number / Numéro du contrat 5000076955
Security Classification / Classification de sécurité Unclassified

PART A (continued) / PARTIE A (suite)

8. Will the supplier require access to PROTECTED and/or CLASSIFIED COMSEC information or assets?
Le fournisseur aura-t-il accès à des renseignements ou à des biens COMSEC désignés PROTÉGÉS et/ou CLASSIFIÉS? No / Non Yes / Oui
If Yes, indicate the level of sensitivity:
Dans l'affirmative, indiquer le niveau de sensibilité :

9. Will the supplier require access to extremely sensitive INFOSEC information or assets?
Le fournisseur aura-t-il accès à des renseignements ou à des biens INFOSEC de nature extrêmement délicate? No / Non Yes / Oui

Short Title(s) of material / Titre(s) abrégé(s) du matériel :
Document Number / Numéro du document :

PART B - PERSONNEL (SUPPLIER) / PARTIE B - PERSONNEL (FOURNISSEUR)

10. a) Personnel security screening level required / Niveau de contrôle de la sécurité du personnel requis

<input type="checkbox"/> RELIABILITY STATUS COTE DE FIABILITÉ	<input type="checkbox"/> CONFIDENTIAL CONFIDENTIEL	<input type="checkbox"/> SECRET SECRET	<input type="checkbox"/> TOP SECRET TRÈS SECRET
<input type="checkbox"/> TOP SECRET- SIGINT TRÈS SECRET - SIGINT	<input type="checkbox"/> NATO CONFIDENTIAL NATO CONFIDENTIEL	<input type="checkbox"/> NATO SECRET NATO SECRET	<input type="checkbox"/> COSMIC TOP SECRET COSMIC TRÈS SECRET
<input type="checkbox"/> SITE ACCESS ACCÈS AUX EMPLACEMENTS			

Special comments:
Commentaires spéciaux : _____

NOTE: If multiple levels of screening are identified, a Security Classification Guide must be provided.
REMARQUE : Si plusieurs niveaux de contrôle de sécurité sont requis, un guide de classification de la sécurité doit être fourni.

10. b) May unscreened personnel be used for portions of the work?
Du personnel sans autorisation sécuritaire peut-il se voir confier des parties du travail? No / Non Yes / Oui
If Yes, will unscreened personnel be escorted?
Dans l'affirmative, le personnel en question sera-t-il escorté? No / Non Yes / Oui

PART C - SAFEGUARDS (SUPPLIER) / PARTIE C - MESURES DE PROTECTION (FOURNISSEUR)

INFORMATION / ASSETS / RENSEIGNEMENTS / BIENS

11. a) Will the supplier be required to receive and store PROTECTED and/or CLASSIFIED information or assets on its site or premises?
Le fournisseur sera-t-il tenu de recevoir et d'entreposer sur place des renseignements ou des biens PROTÉGÉS et/ou CLASSIFIÉS? No / Non Yes / Oui

11. b) Will the supplier be required to safeguard COMSEC information or assets?
Le fournisseur sera-t-il tenu de protéger des renseignements ou des biens COMSEC? No / Non Yes / Oui

PRODUCTION

11. c) Will the production (manufacture, and/or repair and/or modification) of PROTECTED and/or CLASSIFIED material or equipment occur at the supplier's site or premises?
Les installations du fournisseur serviront-elles à la production (fabrication et/ou réparation et/ou modification) de matériel PROTÉGÉ et/ou CLASSIFIÉ? No / Non Yes / Oui

INFORMATION TECHNOLOGY (IT) MEDIA / SUPPORT RELATIF À LA TECHNOLOGIE DE L'INFORMATION (TI)

11. d) Will the supplier be required to use its IT systems to electronically process, produce or store PROTECTED and/or CLASSIFIED information or data?
Le fournisseur sera-t-il tenu d'utiliser ses propres systèmes informatiques pour traiter, produire ou stocker électroniquement des renseignements ou des données PROTÉGÉS et/ou CLASSIFIÉS? No / Non Yes / Oui

11. e) Will there be an electronic link between the supplier's IT systems and the government department or agency?
Disposera-t-on d'un lien électronique entre le système informatique du fournisseur et celui du ministère ou de l'agence gouvernementale? No / Non Yes / Oui



Contract Number / Numéro du contrat 5000076955
Security Classification / Classification de sécurité Unclassified

PART C - (continued) / PARTIE C - (suite)

For users completing the form **manually** use the summary chart below to indicate the category(ies) and level(s) of safeguarding required at the supplier's site(s) or premises.
 Les utilisateurs qui remplissent le formulaire **manuellement** doivent utiliser le tableau récapitulatif ci-dessous pour indiquer, pour chaque catégorie, les niveaux de sauvegarde requis aux installations du fournisseur.

For users completing the form **online** (via the Internet), the summary chart is automatically populated by your responses to previous questions.
 Dans le cas des utilisateurs qui remplissent le formulaire **en ligne** (par Internet), les réponses aux questions précédentes sont automatiquement saisies dans le tableau récapitulatif.

SUMMARY CHART / TABLEAU RÉCAPITULATIF

Category / Catégorie	PROTECTED / PROTÉGÉ			CLASSIFIED / CLASSIFIÉ			NATO				COMSEC					
	A	B	C	CONFIDENTIAL / CONFIDENTIEL	SECRET	TOP SECRET / TRÈS SECRET	NATO RESTRICTED / NATO DIFFUSION RESTREINTE	NATO CONFIDENTIAL / NATO CONFIDENTIEL	NATO SECRET	COSMIC TOP SECRET / COSMIC TRÈS SECRET	PROTECTED / PROTÉGÉ			CONFIDENTIAL / CONFIDENTIEL	SECRET	TOP SECRET / TRÈS SECRET
											A	B	C			
Information / Assets / Renseignements / Biens / Production																
IT Media / Support TI																
IT Link / Lien électronique																

12. a) Is the description of the work contained within this SRCL PROTECTED and/or CLASSIFIED?
 La description du travail visé par la présente LVERS est-elle de nature PROTÉGÉE et/ou CLASSIFIÉE? No / Non Yes / Oui

If Yes, classify this form by annotating the top and bottom in the area entitled "Security Classification".
Dans l'affirmative, classifiez le présent formulaire en indiquant le niveau de sécurité dans la case intitulée « Classification de sécurité » au haut et au bas du formulaire.

12. b) Will the documentation attached to this SRCL be PROTECTED and/or CLASSIFIED?
 La documentation associée à la présente LVERS sera-t-elle PROTÉGÉE et/ou CLASSIFIÉE? No / Non Yes / Oui

If Yes, classify this form by annotating the top and bottom in the area entitled "Security Classification" and indicate with attachments (e.g. SECRET with Attachments).
Dans l'affirmative, classifiez le présent formulaire en indiquant le niveau de sécurité dans la case intitulée « Classification de sécurité » au haut et au bas du formulaire et indiquez qu'il y a des pièces jointes (p. ex. SECRET avec des pièces jointes).

**ANNEX C
FLOOR PLAN(S)**

INSTRUCTIONS TO BIDDERS:

For Category 1a products, the Bidders must provide:

- a) Completed floor plan(s) with proposed SA approved products;
- b) A product listing of proposed SA approved products offered at floor plan(s).
As a minimum the product listing must include the following information:
 - Supplier part numbers including NSA products forming part of this category;
 - brief product descriptions;
 - quantities;
 - firm unit prices
- c) Bidders must provide a stackable panel system that consists of a Base panel with the required add-on module(s) as defined in the panel matrix of this requirement.

***** Products from categories other than Category 1a shown on floor plan are for information purposes only*****

By submitting a bid, the Bidder certifies that their submission includes all components and quantities for Category 1a, in accordance with the floor plans, panel details, panel matrices and/or workstation layouts stipulated in Annex C.

***At contract award, "By submitting a bid, the Bidder" becomes "The Contractor".**

Category 1a Requirement:

1) Floor Plan(s)

See attached pdf floor plan, at ATTACHMENT 1 to ANNEX C

2) Panel Details

- a. All required panel heights: Seated Privacy Add-on Height;
- b. When power is required, the power is located as per the Workstation Typical Package*; should a grouping of workstation types include shared panels and one side is identified as powered and the other side is non-powered, those panels affected must be powered. *Refer to ATTACHMENT 2 to ANNEX C
- c. Type of power feed : Base feed
- d. Component System Accessories:
 1. Panel mounted accessories integrated into the panel frame will be shown on the floor plan Accessories attached to the panel separately must be specified. (Accessory rails, tackable surfaces, whiteboards,...)
 2. When Accessory rails are required, the accessories must be specified: a paper sorter, a tray, a bin, a telephone holder (etc.) (refer to full SA specifications for the information).

3) Panel Matrix or Workstation Layout

See attached Panel Matrix or Workstation layout at ATTACHMENT 2 & ATTACHMENT 3 to ANNEX C

a. Panel Matrix

Refer to Categories 1, 2 and 5 Typical Package for Panel Matrix at ATTACHMENT 3 to ANNEX C

b. Workstation Layout(s)

Refer to Categories 1, 2 and 5 Typicals Package for workstation layout at ATTACHMENT 2 to ANNEX C, and ATTACHMENT 1 to ANNEX C floor plans.

- The floor plan takes precedent over any discrepancies with the workstation layouts.
- When two or more typical workstation types share a common panel spine, the finishes of the interior side of the workstation panel as outlined in the Typical Data Sheets must be followed and **NO PANELS SHALL BE DOUBLED. Where no workstation exists adjacent to typical workstation, refer to Data Sheet for finish.**
- Should one typical workstation identify power and the other does not – power will be required for both. Include Workstation Layouts (in the form of Typical Data Sheets or 3 Dimensional drawings) here or as a separate attachment to this RFB.

ATTACHMENT 1 to ANNEX C
Floor Plans

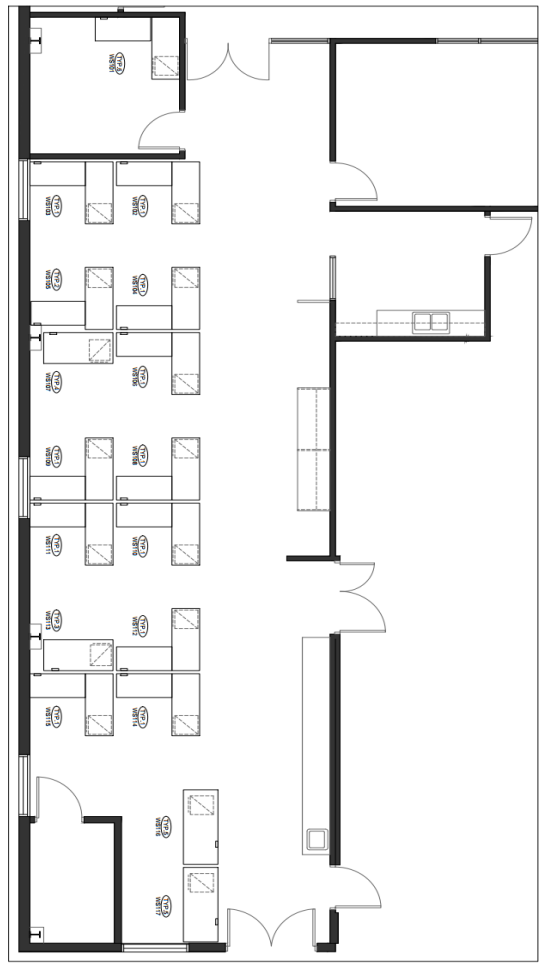

1 FURNITURE PLAN - CATEGORIES 1, 2 & 5
PLAN DU MOBILIER - CATEGORIES 1, 2 ET 5
SCALE = 1:50
ECHELLE = 1:50

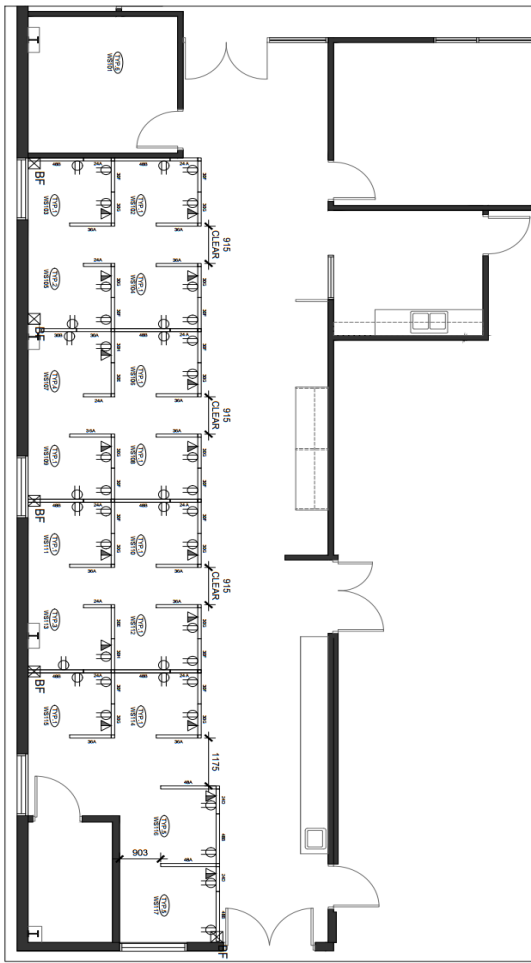

2 FURNITURE PLAN - PANEL LAYOUTS
PLAN DU MOBILIER - AMENAGEMENT DES PANNEAUX
SCALE = 1:50
ECHELLE = 1:50

PROJECT NO.	2526	DRAWING NO.	F-1A
SCALE	1:50		
DRAWN	ML		
CHECKED	DD		
PLOT DATE	2006/02/23	PLOTTED BY	MHEBEN

PROJECT	CNSC Laboratory Office Fit-Up
3848 LIBERTY ROAD	OTTAWA, ON
DRAWING	FURNITURE PLAN, CATEGORIES 1, 2 & 5
	PLAN DU MOBILIER, CATEGORIES 1, 2 ET 5
	5

DATE	2006/02/23
BY	DD
DESCRIPTION	DATE
REV. 1	07/07/2003
REV. 2	07/07/2003
REV. 3	07/07/2003
REV. 4	07/07/2003
REV. 5	07/07/2003
REV. 6	07/07/2003
REV. 7	07/07/2003
REV. 8	07/07/2003
REV. 9	07/07/2003
REV. 10	07/07/2003
REV. 11	07/07/2003
REV. 12	07/07/2003
REV. 13	07/07/2003
REV. 14	07/07/2003
REV. 15	07/07/2003
REV. 16	07/07/2003
REV. 17	07/07/2003
REV. 18	07/07/2003
REV. 19	07/07/2003
REV. 20	07/07/2003
REV. 21	07/07/2003
REV. 22	07/07/2003
REV. 23	07/07/2003
REV. 24	07/07/2003
REV. 25	07/07/2003
REV. 26	07/07/2003
REV. 27	07/07/2003
REV. 28	07/07/2003
REV. 29	07/07/2003
REV. 30	07/07/2003
REV. 31	07/07/2003
REV. 32	07/07/2003
REV. 33	07/07/2003
REV. 34	07/07/2003
REV. 35	07/07/2003
REV. 36	07/07/2003
REV. 37	07/07/2003
REV. 38	07/07/2003
REV. 39	07/07/2003
REV. 40	07/07/2003
REV. 41	07/07/2003
REV. 42	07/07/2003
REV. 43	07/07/2003
REV. 44	07/07/2003
REV. 45	07/07/2003
REV. 46	07/07/2003
REV. 47	07/07/2003
REV. 48	07/07/2003
REV. 49	07/07/2003
REV. 50	07/07/2003



**ATTACHMENT 2 to ANNEX C
Workstation Layout**

Fixed Workstation (TYP.1):

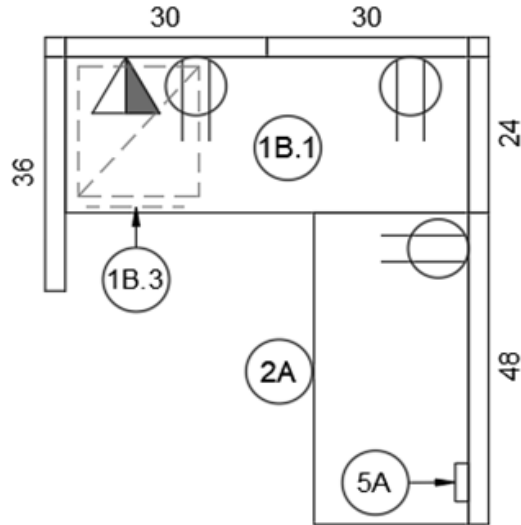
Plan:



Fixed Workstation (TYP.1) Consists of,



Tag	Description
Category 1A – Panels	
Refer to Floor Plans	
Category 1B – Supporting Components and Freestanding Furniture	
1B.1	Fixed Height Rectangular Work Surface, Panel Mounted Width: 1524mm (60") Depth: 609mm (24") Finish: Laminate, Square Edge
1B.3	Pedestal File Width: 381mm (15") Depth: 609mm (24") Finish: Painted Metal
Category 2 – Free Standing Height Adjustable Surfaces	
2A	Individual Height Adjustable Work Surface, Electric, Rectangular, No Privacy Screen Width: 1168mm (46") Depth: 609mm (24") Surface: Laminate, Square Edge
Category 5 – Accessories	
5A	Power Module, 4 Simplex and 2 USB Ports Work Surface Mounted
Electrical Legend	
	Duplex Power Outlet
	Phone/Data Receptacle

Fixed Workstation (TYP.2):

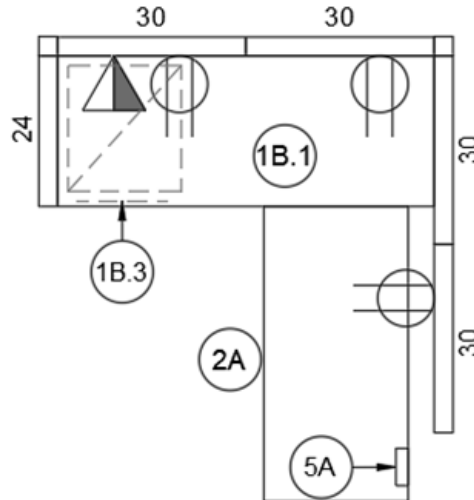
Plan:



Fixed Workstation (TYP.2) Consists of,



Tag	Description
Category 1A – Panels	
Refer to Floor Plans	
Category 1B – Supporting Components and Freestanding Furniture	
1B.1	Fixed Height Rectangular Work Surface, Panel Mounted Width: 1524mm (60") Depth: 609mm (24") Finish: Laminate, Square Edge
1B.3	Pedestal File Width: 381mm (15") Depth: 609mm (24") Finish: Laminate
Category 2 – Free Standing Height Adjustable Surfaces	
2A	Individual Height Adjustable Work Surface, Electric, Rectangular, No Privacy Screen Width: 1168mm (46") Depth: 609mm (24") Surface: Laminate, Square Edge
Category 5 – Accessories	
5A	Power Module, 4 Simplex and 2 USB Ports Work Surface Mounted
Electrical Legend	
	Duplex Power Outlet
	Phone/Data Receptacle

Fixed Workstation (TYP.3):

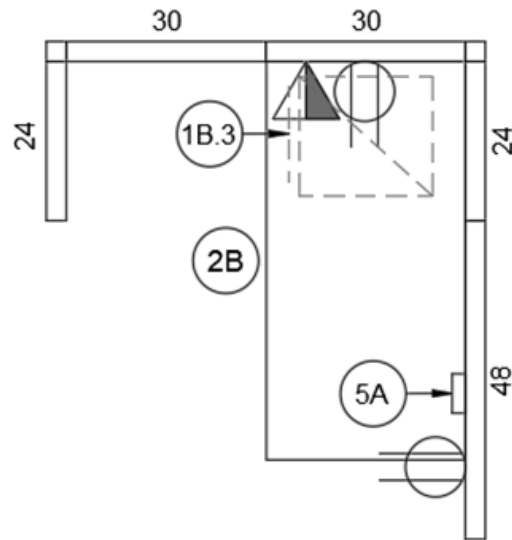
Plan:



Fixed Workstation (TYP.3) Consists of,



Tag	Description
Category 1A – Panels	
Refer to Floor Plans	
Category 1B – Supporting Components and Freestanding Furniture	
1B.3	Pedestal File Width: 381mm (15") Depth:609mm (24") Finish: Laminate
Category 2 – Free Standing Height Adjustable Surfaces	
2B	Individual Height Adjustable Work Surface, Electric, Rectangular, No Privacy Screen Width: 1524mm (60") Depth: 762mm (30") Surface: Laminate, Square Edge
Category 5 – Accessories	
5A	Power Module, 4 Simplex and 2 USB Ports Work Surface Mounted
Electrical Legend	
	Duplex Power Outlet
	Phone/Data Receptacle

Fixed Workstation (TYP.4):

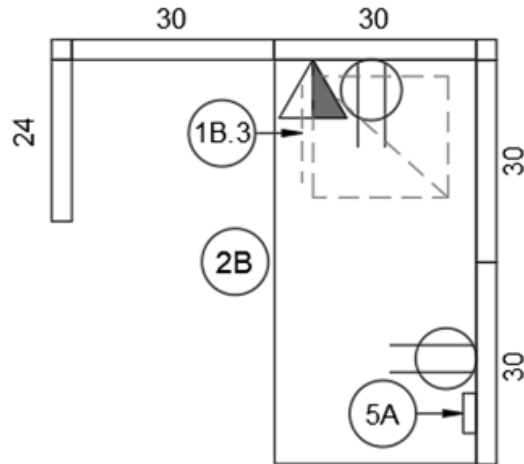
Plan:



Fixed Workstation (TYP. 4) Consists of,

Tag	Description
Category 1A – Panels	
Refer to Floor Plans	
Category 1B – Supporting Components and Freestanding Furniture	
1B.3	Pedestal File Width: 381mm (15") Depth:609mm (24") Finish: Laminate
Category 2 – Free Standing Height Adjustable Surfaces	
2B	Individual Height Adjustable Work Surface, Electric, Rectangular, No Privacy Screen Width: 1524mm (60") Depth: 762mm (30") Surface: Laminate, Square Edge
Category 5 – Accessories	
5A	Power Module, 4 Simplex and 2 USB Ports Work Surface Mounted
Electrical Legend	
	Duplex Power Outlet
	Phone/Data Receptacle

▲ Freestanding Workstation (TYP.6):

Plan:

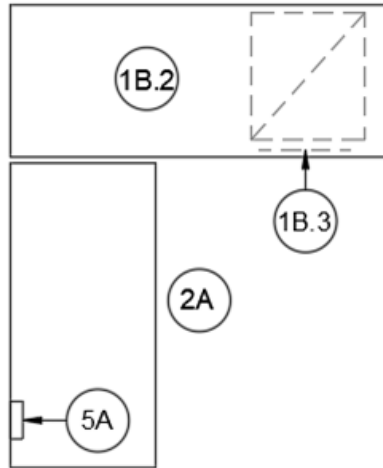

Freestanding Workstation (TYP.6) Consists of,

Tag	Description
Category 1B – Supporting Components and Freestanding Furniture	
1B.2	Fixed Height Rectangular Work Surface, Post Legs Width: 1524mm (60") Depth: 609mm (24") Finish: Laminate, Square Edge
1B.3	Pedestal File Width: 381mm (15") Depth: 609mm (24") Finish: Laminate
Category 2 – Free Standing Height Adjustable Surfaces	
2A	Individual Height Adjustable Work Surface, Electric, Rectangular, No Privacy Screen Width: 1168mm (46") Depth: 609mm (24") Surface: Laminate, Square Edge
Category 5 – Accessories	
5A	Power Module, 4 Simplex and 2 USB Ports Work Surface Mounted

**ATTACHMENT 3 to ANNEX C
Panel Matrix**

Panel Type: A

Seated Privacy Height, Non-Powered

<i>upper element 1 Fabric (Grade A)</i>	<i>upper element 2 Fabric (Grade A)</i>
<i>lower element 1 Fabric (Grade A)</i>	<i>lower element 2 Fabric (Grade A)</i>
<i>Side 1</i>	<i>Side 2</i>

Panel Type: B

Seated Privacy Height, Powered

<i>upper element 1 Fabric (Grade A)</i>	<i>upper element 2 Fabric (Grade A)</i>
<i>lower element 1 Fabric (Grade A) Cut-Outs for Power Only (Below Worksurface, At Base of Panel Preferred)</i>	<i>lower element 2 Fabric (Grade A)</i>
<i>Side 1</i>	<i>Side 2</i>

Panel Type: C

Seated Privacy Height, Powered

<i>upper element 1 Fabric (Grade A)</i>	<i>upper element 2 Fabric (Grade A)</i>
<i>lower element 1 Fabric (Grade A) Cut-Outs for Power and Data (Above Worksurface)</i>	<i>lower element 2 Fabric (Grade A)</i>
<i>Side 1</i>	<i>Side 2</i>

Panel Type: D

Seated Privacy Height, Powered

<i>upper element 1 Fabric (Grade A)</i>	<i>upper element 2 Fabric (Grade A)</i>
<i>lower element 1 Fabric (Grade A) Cut-Outs for Power Only (Above Worksurface)</i>	<i>lower element 2 Fabric (Grade A)</i>
<i>Side 1</i>	<i>Side 2</i>

Panel Type: E

Seated Privacy Height, Non-Powered

<i>upper element 1 Frosted Glazed</i>	<i>upper element 2 Frosted Glazed</i>
<i>lower element 1 Fabric (Grade A)</i>	<i>lower element 2 Fabric (Grade A)</i>
<i>Side 1</i>	<i>Side 2</i>

Panel Type: F

Seated Privacy Height, Powered

<i>upper element 1 Frosted Glazed</i>	<i>upper element 2 Frosted Glazed</i>
<i>lower element 1 Fabric (Grade A) Cut-Outs for Power Only (Below Worksurface, At Base of Panel Preferred)</i>	<i>lower element 2 Fabric (Grade A)</i>
<i>Side 1</i>	<i>Side 2</i>

Panel Type: G
Seated Privacy Height, Powered

<i>upper element 1</i> <i>Frosted Glazed</i>	<i>upper element 2</i> <i>Frosted Glazed</i>
<i>lower element 1</i> <i>Fabric (Grade A)</i> <i>Cut-Outs for Power</i> <i>and Data (Above</i> <i>Worksurface)</i>	<i>lower element 2</i> <i>Fabric (Grade A)</i>

Side 1

Side 2

Panel Type: H
Seated Privacy Height, Powered

<i>upper element 1</i> <i>Frosted Glazed</i>	<i>upper element 2</i> <i>Frosted Glazed</i>
<i>lower element 1</i> <i>Fabric (Grade A)</i> <i>Cut-Outs for Power</i> <i>Only (Above</i> <i>Worksurface)</i>	<i>lower element 2</i> <i>Fabric (Grade A)</i>

Side 1

Side 2